

1/10 LUXURY ELECTRIC STADIUM TRUCK

# XTRAY XT2

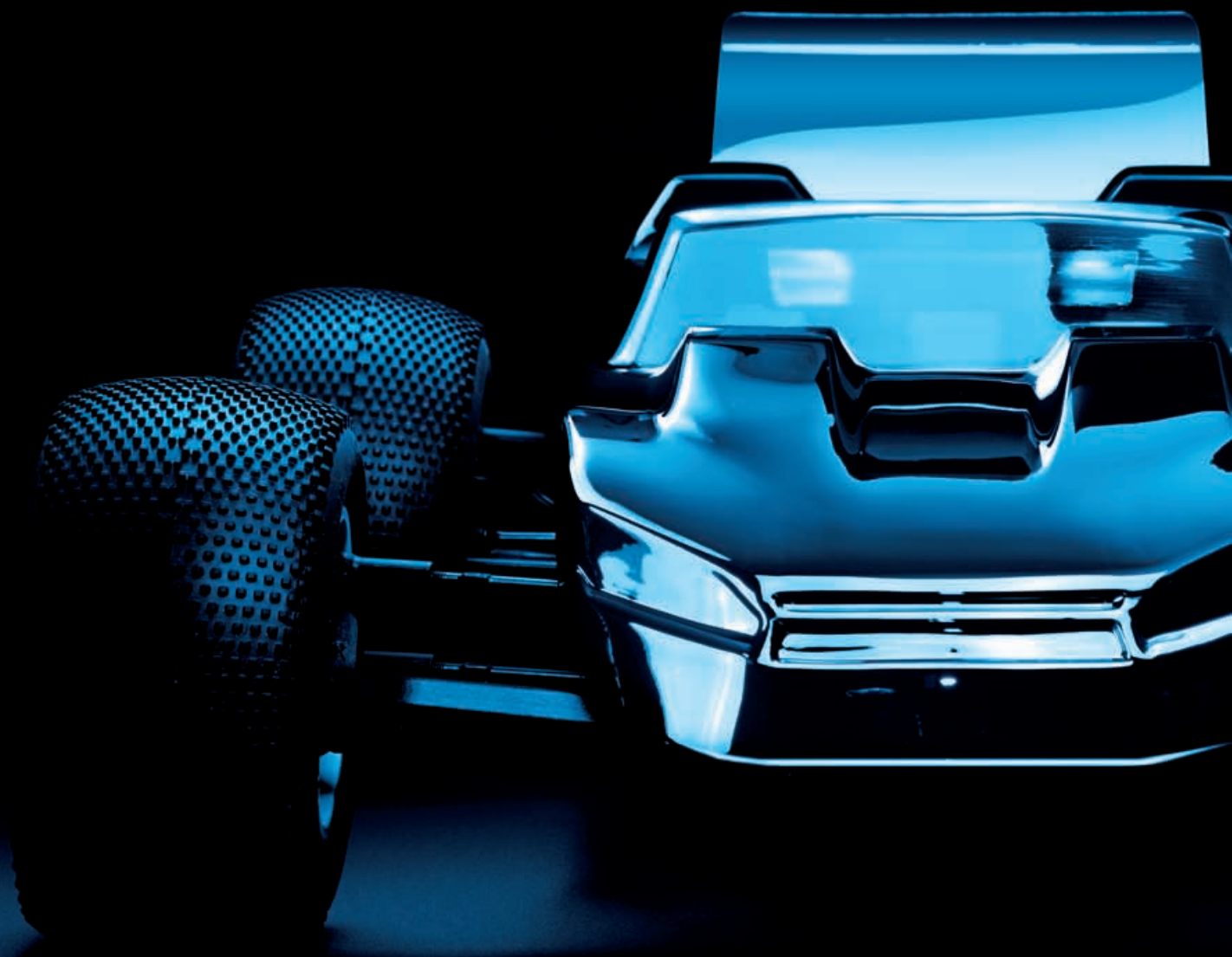

**INSTRUCTION MANUAL**  
FOR XT2C'23 & XT2D'23 EDITION

## BEFORE YOU START

This is a high-competition, high-quality RC car intended for persons aged 16 years and older with previous experience building and operating RC model racing cars. This is not a toy; it is a precision racing model. This model racing car is not intended for use by beginners, inexperienced customers, or by children without direct supervision of a responsible, knowledgeable adult. If you do not fulfill these requirements, please return the kit in unused and unassembled form back to the shop where you have purchased it.

Before building and operating your XRAY, YOU MUST read through all of the operating instructions and instruction manual and fully understand them to get the maximum enjoyment and prevent unnecessary damage.

## CUSTOMER SUPPORT

We have made every effort to make these instructions as easy to understand as possible. However, if you have any difficulties, problems, or questions, please do not hesitate to contact the XRAY support team at [info@teamxray.com](mailto:info@teamxray.com). Also, please visit our Web site at [www.teamxray.com](http://www.teamxray.com) to find the latest updates, set-up information, option parts, and many other goodies. We pride ourselves on taking excellent care of our customers.

You can join thousands of XRAY fans and enthusiasts in our online community at:

[www.teamxray.com](http://www.teamxray.com)

Read carefully and fully understand the instructions before beginning assembly.

Make sure you review this entire manual, download and use set-up book from the web, and examine all details carefully. If for some reason you decide this is not what you wanted or expected, do not continue any further. Your hobby dealer can not accept your kit for return or exchange after it has been partially or fully assembled.

Contents of the box may differ from pictures. In line with our policy of continuous product development, the exact specifications of the kit may vary without prior notice.

### XRAY Europe

K Vystavisku 6992  
91101 Trenčín  
Slovakia, EUROPE  
Phone: 421-32-7401100  
Fax: 421-32-7401109  
E-mail: [info@teamxray.com](mailto:info@teamxray.com)

### XRAY USA

RC America, 2030 Century Center Blvd #15  
Irving, TX 75062  
USA  
Phone: (214) 744-2400  
Fax: (214) 744-2401  
E-mail: [xray@rcamerica.com](mailto:xray@rcamerica.com)

**FAILURE TO FOLLOW THESE INSTRUCTIONS WILL BE CONSIDERED AS ABUSE AND/OR NEGLIGENCE.**

## SAFETY PRECAUTIONS

Contains:

LEAD (CAS 7439-92-1) ANTIMONY (CAS 7440-36-0)

WARNING: This product contains a chemical known to the state of California to cause cancer and birth defects or other reproductive harm.

CAUTION: CANCER HAZARD

Contains lead, a listed carcinogen. Lead is harmful if ingested. Wash thoroughly after using. DO NOT use product while eating, drinking or using tobacco products. May cause chronic effects to gastrointestinal tract, CNS, kidneys, and blood. MAY CAUSE BIRTH DEFECTS.

When building, using and/or operating this model always wear protective glasses and gloves.

Take appropriate safety precautions prior to operating this model. You are responsible for this model's assembly and safe operation! Please read the instruction manual before building and operating this model and follow all safety precautions. Always keep the instruction manual at hand for quick

reference, even after completing the assembly. Use only genuine and original authentic XRAY parts for maximum performance. Using any third party parts on this model will void guaranty immediately.

Improper operation may cause personal and/or property damage. XRAY and its distributors have no control over damage resulting from shipping, improper construction, or improper usage. XRAY assumes and accepts no responsibility for personal and/or property damages resulting from the use of improper building materials, equipment and operations. By purchasing any item produced by XRAY, the buyer expressly warrants that he/she is in compliance with all applicable federal, state and local laws and regulation regarding the purchase, ownership and use of the item. The buyer expressly agrees to indemnify and hold harmless XRAY for all claims resulting directly or indirectly from the purchase, ownership or use of the product. By the act of assembling or operating this product, the user accepts all resulting liability. If the buyer is not prepared to accept this liability, then he/she should return this kit in new, unassembled, and unused condition to the place of purchase.



## IMPORTANT NOTES - GENERAL

- This product is not suitable for children under 16 years of age without the direct supervision of a responsible and knowledgeable adult.
- Carefully read all manufacturers warnings and cautions for any parts used in the construction and use of your model.
- Assemble this kit only in places away from the reach of very small children.
- First-time builders and users should seek advice from people who have building experience in order to assemble the model correctly and to allow the model to reach its performance potential.
- Exercise care when using tools and sharp instruments.
- Take care when building, as some parts may have sharp edges.
- Keep small parts out of reach of small children. Children must not be allowed to put any parts in their mouth, or pull vinyl bag over their head.
- Read and follow instructions supplied with paints and/or cement, if used (not included in kit).
- Immediately after using your model, DO NOT touch equipment on the model such as the motor and speed controller, because they generate high temperatures. You may seriously burn yourself seriously touching them.
- Follow the operating instructions for the radio equipment at all times.
- Do not put fingers or any objects inside rotating and moving parts, as this may cause damage or serious injury as your finger, hair, clothes, etc. may get caught.
- Be sure that your operating frequency is clear before turning on or running your model, and never share the same frequency with somebody else at the same time. Ensure that others are aware of the operating frequency you are using and when you are using it.
- Use a transmitter designed for ground use with RC cars. Make sure that no one else is using the same frequency as yours in your operating area. Using the same frequency at the same time, whether it is driving, flying or sailing, can cause loss of control of the RC model, resulting in a serious accident.
- Always turn on your transmitter before you turn on the receiver in the car. Always turn off the receiver before turning your transmitter off.
- Keep the wheels of the model off the ground when checking the operation of the radio equipment.

- Disconnect the battery pack before storing your model.
- When learning to operate your model, go to an area that has no obstacles that can damage your model if your model suffers a collision.
- Remove any sand, mud, dirt, grass or water before putting your model away.
- If the model behaves strangely, immediately stop the model, check and clear the problem.
- To prevent any serious personal injury and/or damage to property, be responsible when operating all remote controlled models.
- The model car is not intended for use on public places and roads or areas where its operation can conflict with or disrupt pedestrian or vehicular traffic.
- Because the model car is controlled by radio, it is subject to radio interference from many sources that are beyond your control. Since radio interference can cause momentary loss of control, always allow a safety margin in all directions around the model in order to prevent collisions.
- Do not use your model:
  - Near real cars, animals, or people that are unaware that an RC car is being driven.
  - In places where children and people gather
  - In residential districts and parks
  - In limited indoor spaces
  - In wet conditions
  - In the street
  - In areas where loud noises can disturb others, such as hospitals and residential areas.
  - At night or anytime your line of sight to the model may be obstructed or impaired in any way.

To prevent any serious personal injury and/or damage to property, please be responsible when operating all remote controlled models.

## **IMPORTANT NOTES - ELECTRICAL**

- Insulate any exposed electrical wiring (using heat shrink tubing or electrical tape) to prevent dangerous short circuits. Take maximum care in wiring, connecting and insulating cables. Make sure cables are always connected securely. Check connectors for if they become loose. And if so, reconnect them securely. Never use RC models with damaged wires. A damaged wire is extremely dangerous, and can cause short-circuits resulting in fire. Please have wires repaired at your local hobby shop.
- Low battery power will result in loss of control. Loss of control can occur due to a weak battery in either the transmitter or the receiver. Weak running battery may also result in an out of control car if your car's receiver power is supplied by the running battery. Stop operation immediately if the car starts to slow down.
- When not using RC model, always disconnect and remove battery.
- Do not disassemble battery or cut battery cables. If the running battery short-circuits, approximately 300W of electricity can be discharged, leading to fire or burns. Never disassemble battery or cut battery cables.
- Use a recommended charger for the receiver and transmitter batteries and follow the instructions correctly. Over-charging, incorrect charging,

or using inferior chargers can cause the batteries to become dangerously hot. Recharge battery when necessary. Continual recharging may damage battery and, in the worst case, could build up heat leading to fire. If battery becomes extremely hot during recharging, please ask your local hobby shop for check and/or repair and/or replacement.

- Regularly check the charger for potential hazards such as damage to the cable, plug, casing or other defects. Ensure that any damage is rectified before using the charger again. Modifying the charger may cause short-circuit or overcharging leading to a serious accident. Therefore do not modify the charger.
- Always unplug charger when recharging is finished.
- Do not recharge battery while battery is still warm. After use, battery retains heat. Wait until it cools down before charging.
- Do not allow any metal part to short circuit the receiver batteries or other electrical/electronic device on the model.
- Immediately stop running if your RC model gets wet as may cause short circuit.
- Please dispose of batteries responsibly. Never put batteries into fire.

## **R/C & BUILDING TIPS**

- Make sure all fasteners are properly tightened. Check them periodically.
- Make sure that chassis screws do not protrude from the chassis.
- For the best performance, it is very important that great care is taken to ensure the free movement of all parts.
- Clean all ball-bearings so they move very easily and freely.
- Tap or pre-thread the plastic parts when threading screws.
- Self-tapping screws cut threads into the parts when being tightened. Do not use excessive force when tightening the self-tapping screws because you may strip out the thread in the plastic. We recommended you stop tightening a screw when you feel some resistance.
- Ask your local hobby shop for any advice.

Please support your local hobby shop. We at XRAY Model Racing Cars support all local hobby dealers. Therefore we ask you, if at all possible, to purchase XRAY products at your hobby dealer and give them your support like we do. If you have difficulty finding XRAY products, please check out [www.teamxray.com](http://www.teamxray.com) to get advice, or contact us via email at [info@teamxray.com](mailto:info@teamxray.com), or contact the XRAY distributor in your country.

## **WARRANTY**

XRAY guarantees this model kit to be free from defects in both material and workmanship within 30 days of purchase. The total monetary value under warranty will in no case exceed the cost of the original kit purchased. This warranty does not cover any components damaged by use or modification or as a result of wear. Part or parts missing from this kit must be reported within 30 days of purchase. No part or parts will be sent under warranty without proof of purchase. Should you find a defective or missing part, contact the local distributor. Service and customer support will be provided through local hobby store where you have purchased the kit, therefore make sure to purchase any XRAY products at your local hobby store. This model racing car is considered to be a high-performance racing vehicle. As such this vehicle will be used in an extreme range of conditions and situations, all which may cause premature wear or failure of any component. XRAY has no control over usage of vehicles once they leave the dealer, therefore XRAY can only offer warranty against all manufacturer's defects in materials, workmanship, and assembly at point of sale and before use. No warranties are expressed or implied that cover damage caused by what is considered normal use, or cover or imply how long any model cars' components or electronic components will last before requiring replacement.

Due to the high performance level of this model car you will need to periodically maintain and replace consumable components. Any and all warranty coverage will not cover replacement of any part or component damaged by neglect, abuse, or improper or unreasonable use. This includes

but is not limited to damage from crashing, chemical and/or water damage, excessive moisture, improper or no maintenance, or user modifications which compromise the integrity of components. Warranty will not cover components that are considered consumable on RC vehicles. XRAY does not pay nor refund shipping on any component sent to XRAY or its distributors for warranty. XRAY reserves the right to make the final determination of the warranty status of any component or part.

### **Limitations of Liability**

XRAY makes no other warranties expressed or implied. XRAY shall not be liable for any loss, injury or damages, whether direct, indirect, special, incidental, or consequential, arising from the use, misuse, or abuse of this product and/or any product or accessory required to operate this product. In no case shall XRAY's liability exceed the monetary value of this product.

**Take adequate safety precautions prior to operating this model. You are responsible for this model's assembly and safe operation.**

**Disregard of the any of the above cautions may lead to accidents, personal injury, or property damage. XRAY MODEL RACING CARS assumes no responsibility for any injury, damage, or misuse of this product during assembly or operation, nor any additions that may arise from the use of this product.**

**All rights reserved.**

## **QUALITY CERTIFICATE**

XRAY MODEL RACING CARS uses only the highest quality materials, the best compounds for molded parts and the most sophisticated manufacturing processes of TQM (Total Quality Management). We guarantee that all parts of a newly-purchased kit are manufactured with the highest regard to quality. However, due to the many factors inherent in model racecar competition, we

cannot guarantee any parts once you start racing the car. Products which have been worn out, abused, neglected or improperly operated will not be covered under warranty.

We wish you enjoyment of this high-quality and high-performance RC car and wish you best success on the track!

**In line with our policy of continuous product development, the exact specifications of the kit may vary. In the unlikely event of any problems with your new kit, you should contact the model shop where you purchased it, quoting the part number.**

**We do reserve all rights to change any specification without prior notice. All rights reserved.**

# TOOLS REQUIRED



Combination Pliers  
(HUDY #189020)



Side Cutters  
(HUDY #189010)



Pocket Hobby Knife (HUDY #188981)



Special Tool for turnbuckles, nuts (HUDY #181090)



Turnbuckle Wrench 3mm (HUDY #181030)



Allen 1.5mm (#111545 - HUDY EXCLUSIVE Limited Edition)



Allen 2.0mm (#112045 - HUDY EXCLUSIVE Limited Edition)

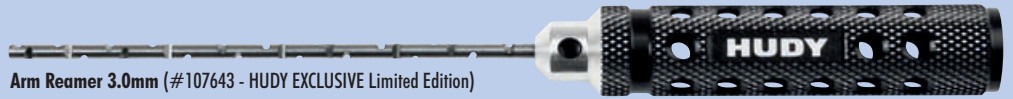

Arm Reamer 3.0mm (#107643 - HUDY EXCLUSIVE Limited Edition)



Socket 5.5mm (#175535 - HUDY EXCLUSIVE Limited Edition)

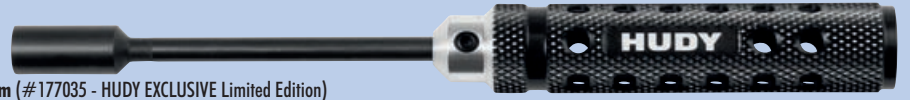

Socket 7.0mm (#177035 - HUDY EXCLUSIVE Limited Edition)

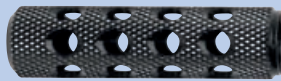

Reamer (#107602 - HUDY EXCLUSIVE Limited Edition)



Scissors (HUDY #188990)



Professional Multi Tool  
(HUDY #183011)



Tweezer

# EQUIPMENT INCLUDED \* Kit includes smaller but sufficient amount of oil and grease to build the car.

650cSt (#106365)  
HUDY Premium  
Silicone Oils



500cSt (#106350)  
HUDY Premium  
Silicone Oils



10.000cSt (#106510)  
HUDY Premium  
Silicone Oils



(HUDY #106211)  
Premium  
Diff Grease



(HUDY #106210)  
Premium  
Graphite Grease



# EQUIPMENT REQUIRED

Transmitter



Receiver



Speed Controller



Steering Servo



Electric Motor & Pinion Gear  
with Setscrew



LiPo Battery



Battery Charger



Double-sided Tape  
(HUDY #107875)



Lexan™ Paint



4x Tires & Inserts



Bearing Oil  
(HUDY #106230)



Threadlock



CA glue



# NOT INCLUDED



**Follow Set-Up Book:**  
To ensure that you always have access to the most up-to-date version of the Set-up Book you can download the HUDY Set-up Book from their web site at [www.hudy.net] By offering this online version instead of including a hardcopy printed version in kits, you will always be assured of having the most current updated version.



SAMPLE OF OPTIONAL PARTS		
#32XXXX	TYPE1	OPTION 1
#32XXXX	TYPE1	OPTION 2
#32XXXX	TYPE1	INCLUDED

XRAY offers wide range of optional tuning parts which are listed in a table like this. Please refer to the exploded view of each main section to verify which part is included in the kit while all other parts are available only as an optional part and must be purchased separately.

## COLOR INDICATIONS

At the beginning of each section is an exploded view of the parts to be assembled. There is also a list of all the parts and part numbers that are related to the assembly of that section.

The part descriptions are color-coded to make it easier for you to identify the source of a part. Here are what the different colors mean:

- 321200** **STYLE A** - indicates parts that are included in the bag marked for the section.
- 321100** **STYLE B** - indicates parts that are included in the box.
- 324900** **STYLE C** - indicates parts that are already assembled from previous steps.

## TECH TIPS

### TIP DRIVE SHAFT PIN SERVICING

To enjoy the longest possible lifespan of the drive shafts and diff outdrives, it is extremely important to properly service the drive shaft pins. Inspect the pins after every 3 hours of runtime. If the pins show any wear, replace them with new pins.



DO NOT use drive shafts when the pins are worn.

Press out the worn pins.

Press in new pins and regularly inspect for wear.



For quick & easy drive pin replacements use #106000 HUDY Drive Pin Replacement Tool together with #106036 Ejector Pivot Pin & Alternating Pivot 2.5mm.



To replace the worn pins use only premium HUDY drive pins #106053.

### MANUAL STEPS ONLY FOR DIRT

**1. BALL DIFFERENTIAL** **DIRT**

SAC

### MANUAL STEPS ONLY FOR CARPET

**1. GEAR DIFFERENTIAL** **CARPET**

SAC

### MANUAL DUAL STEPS FOR CARPET AND DIRT

**3. REAR DRIVETRAIN** **CARPET** **DIRT**

# 1. GEAR DIFFERENTIAL

**#325100 XRAY ACTIVE DIFFERENTIAL - SET**  
OPTION



OPTION

**ACTIVE DIFF SEGMENTS**

#325123	60°		OPTION
#325125	90°		OPTION
#325127	120°		INCLUDED

OPTION

**GEAR DIFF CASES**

#324911	HARD	INCLUDED
#324911-G	GRAPHITE	OPTION
<b>GEAR DIFF PULLEYS</b>		
#324954	HARD	INCLUDED
#324954-G	GRAPHITE	OPTION

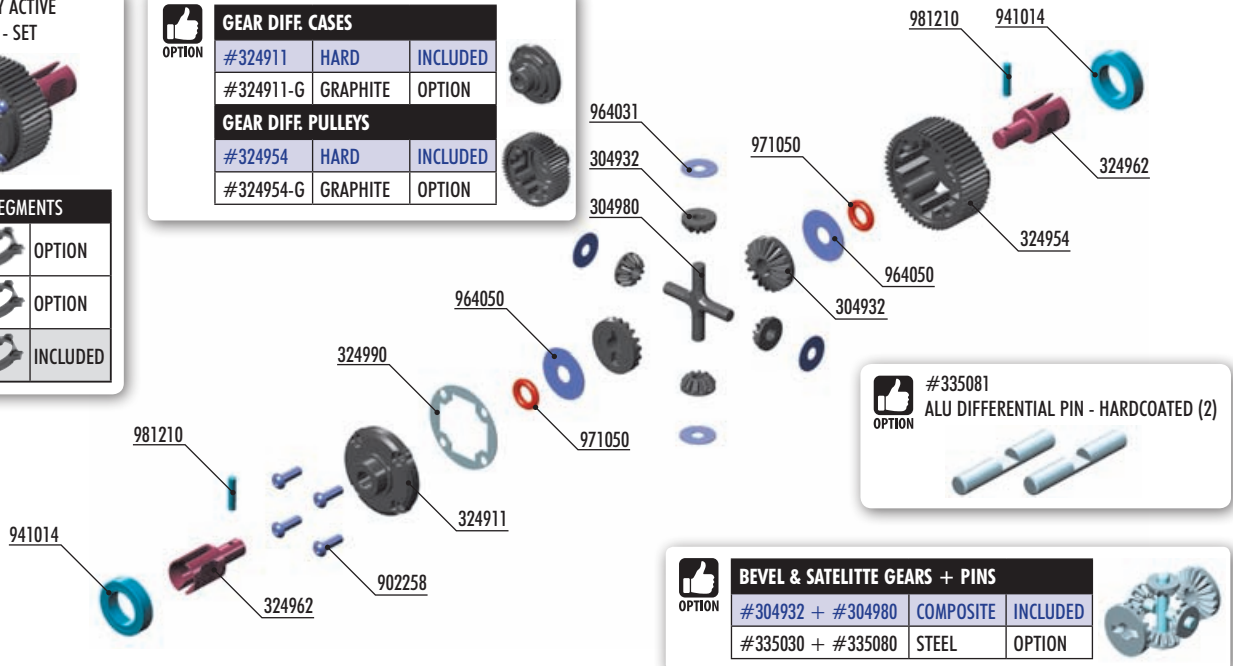

OPTION

**#335081 ALU DIFFERENTIAL PIN - HARDCOATED (2)**



OPTION

**BEVEL & SATELLITE GEARS + PINS**

#304932 + #304980	COMPOSITE	INCLUDED
#335030 + #335080	STEEL	OPTION



**BAG**

**01**

- 304932 GRAPHITE GEAR DIFF BEVEL & SATELLITE GEARS (2+4)
- 304980 COMPOSITE GEAR DIFF CROSS PIN
- 324990 DIFF GASKET (4)
- 324902 GEAR DIFFERENTIAL - LCG - SET
- 324911 COMPOSITE GEAR DIFFERENTIAL COVER - LCG
- 324954 COMPOSITE GEAR DIFFERENTIAL CASE - LCG - 53T
- 324962 GEAR DIFF OUTDRIVE ADAPTER - LCG - HUDY SPRING STEEL™ (2)

- 902258 HEX SCREW SH M2.5x8 (10)
- 941014 BALL-BEARING 10x15x4 RUBBER SEALED - GREASE (2)
- 964031 WASHER S 3.5x10x0.2 (10)
- 964050 WASHER S 5x15x0.3 (10)
- 971050 SILICONE O-RING 5x1.5 (10)
- 981210 PIN 2x10 (10)

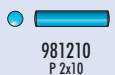

**2x**

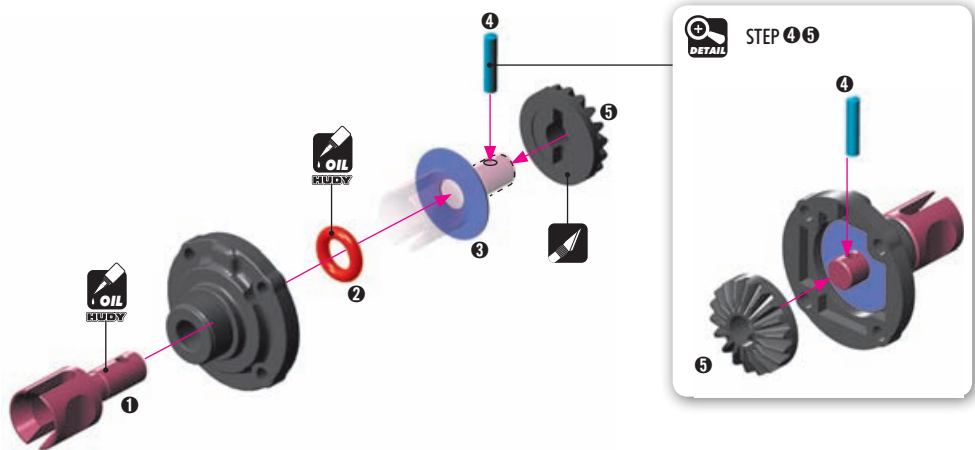

**STEP 4 5**

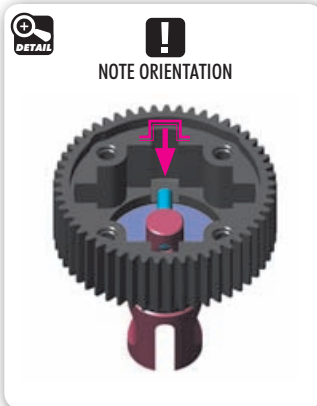

Use tweezers to insert pin

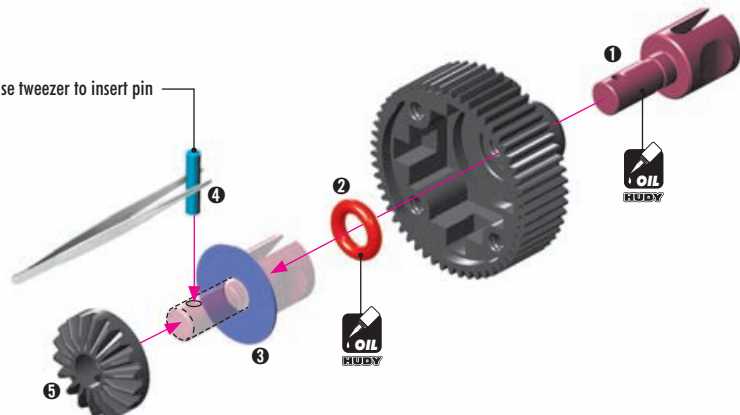



964031  
S 3.5x10x0.2

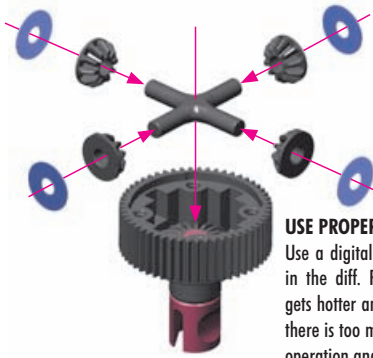

### USE PROPER AMOUNT OF OIL IN THE DIFFS

Use a digital scale to measure the exact amount of oil in the diff. Remember that during operation the diff gets hotter and the heat may allow the oil to expand. If there is too much oil inside it may interfere with the diff operation and damage the internal gears.



### Rear diff

Silicone oil 10.000cSt  
Fill just above the diff pin.



Fill differential up to the top of the diff pin.



DO NOT fill the diff to the top of the housing.



TO ENSURE YOU HAVE THE SAME AMOUNT OF OIL FROM REBUILD TO REBUILD, DO THE FOLLOWING:



1 Put the diff (without oil) on the scale and check the weight (approximately 11.92g)

$$11.92g + 1.30g = 13.22g$$

#107865  
HUDY Ultimate Digital Pocket Scale 300g ± 0.01g



2 Slowly pour oil into the diff and watch the weight. Add 1.30g of oil into the diff. The approximate weight of the diff including oil is 13.22g.

### TIP TIPS FOR REAR DIFFERENTIAL

LOW-MEDIUM TRACTION 10.000cSt (HUDY #106510)  
MEDIUM-HIGH TRACTION 15.000cSt (HUDY #106515)

**NOTE:** Softer oil increases rear traction, harder oil increases on-power steering.



### HUDY ULTIMATE SILICONE OILS

OPTION	Oil Type	Volume	Status
#106450	5.000cSt	50ml	OPTION
#106460	6.000cSt	50ml	OPTION
#106470	7.000cSt	50ml	OPTION
#106480	8.000cSt	50ml	OPTION
#106490	9.000cSt	50ml	OPTION
#106510	10.000cSt	50ml	INCLUDED
#106492	11.000cSt	50ml	OPTION
#106512	12.000cSt	50ml	OPTION
#106515	15.000cSt	50ml	INCLUDED
#106520	20.000cSt	50ml	INCLUDED

### SET-UP BOOK

DIFFERENTIAL OIL



902258  
SH M2.5x8

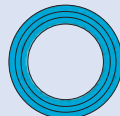

941014  
BB 10x15x4



Tighten the screws equally but DO NOT tighten them completely.

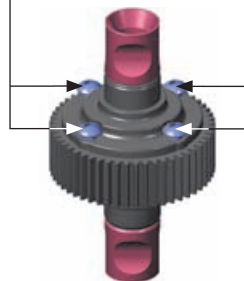

Finish tightening in this order.

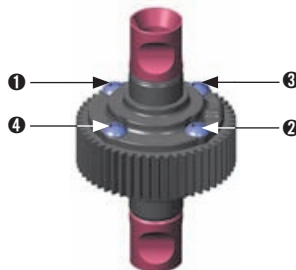

Use HUDY Ball-Bearing Grease

#106220 - STANDARD  
#106221 - BLUE  
#106222 - RED

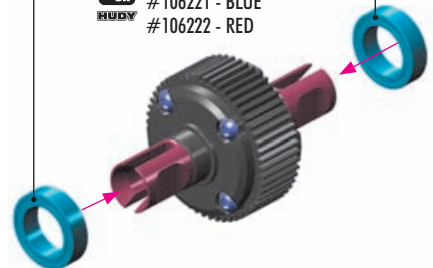

# 1. BALL DIFFERENTIAL



#325100 XRAY ACTIVE DIFFERENTIAL - SET



### ACTIVE DIFF SEGMENTS

#325123	60°		OPTION
#325125	90°		OPTION
#325127	120°		INCLUDED

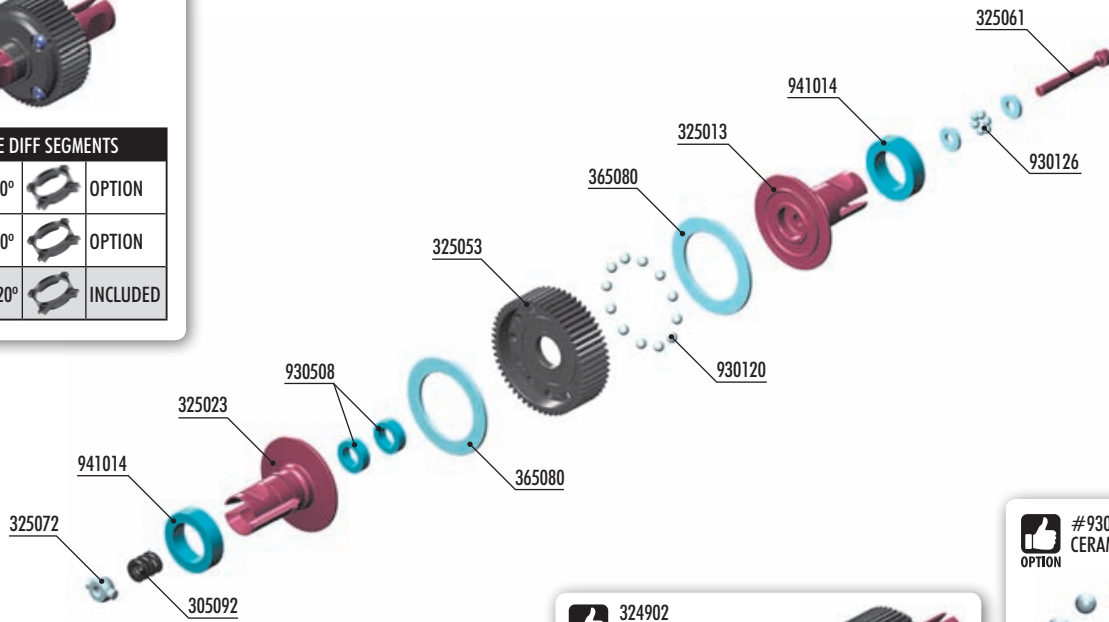

324902 GEAR DIFFERENTIAL - LCG - SET



#930220 CERAMIC BALL 2.4MM (12)



BAG

01

- |        |   |        |   |
|--------|---|--------|---|
| 305092 | BALL DIFFERENTIAL SPRING  | 325072 | ALU BALL DIFFERENTIAL NUT                       |
| 325003 | BALL ADJUSTABLE DIFFERENTIAL - LCG - SET - HUDY SPRING STEEL™   | 365080 | DIFF WASHER 17 x 24.5 x 1 (2)                   |
| 325013 | BALL DIFFERENTIAL SHORT OUTPUT SHAFT - LCG - HUDY SPRING STEEL™ | 930120 | CARBIDE BALL 2.4MM FOR BALL DIFF (12)           |
| 325023 | BALL DIFFERENTIAL LONG OUTPUT SHAFT - LCG - HUDY SPRING STEEL™  | 930126 | CARBIDE BALL-BEARING AXIAL 2.6x6x1              |
| 325053 | COMPOSITE BALL DIFFERENTIAL GEAR 53T                            | 930508 | BALL-BEARING 5x8x2.5 STEEL SEALED - OIL (2)     |
| 325061 | SCREW FOR BALL DIFF ADJUSTMENT - SPRING STEEL™                  | 941014 | BALL-BEARING 10x15x4 RUBBER SEALED - GREASE (2) |



930126  
BA 2.6x6x1

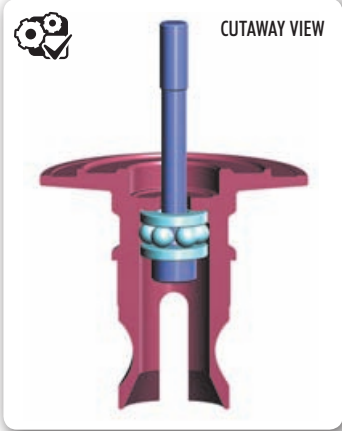
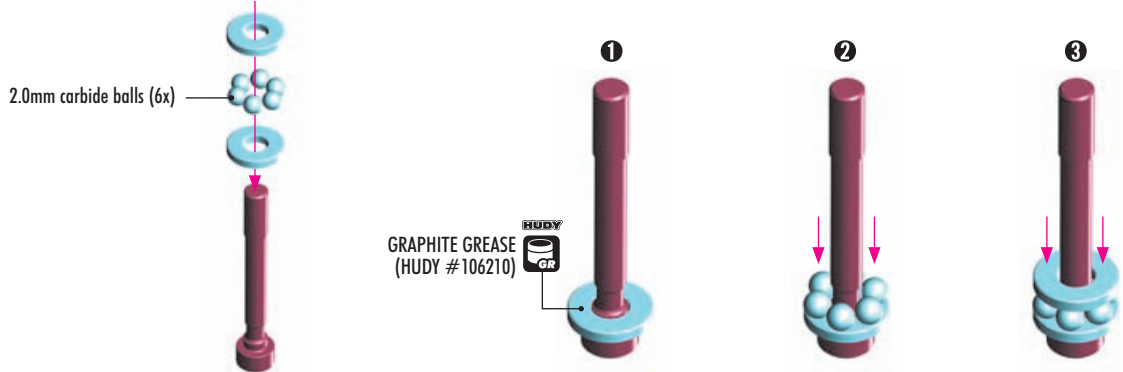



# 1. BALL DIFFERENTIAL



930508  
BB 5x8x2.5

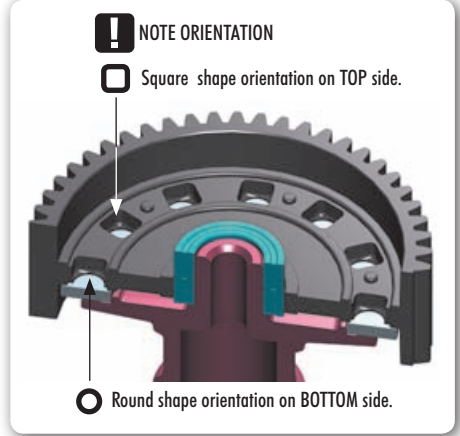
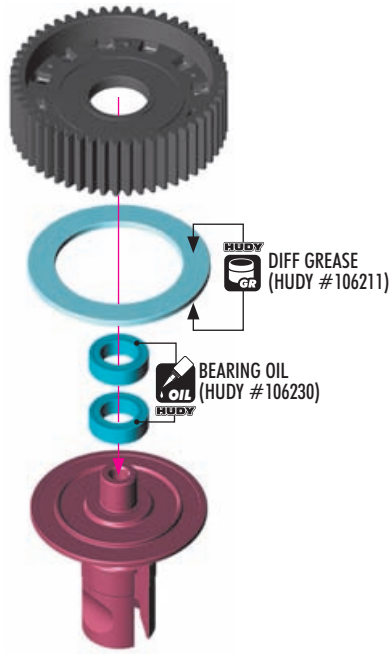

930120  
B 2.4

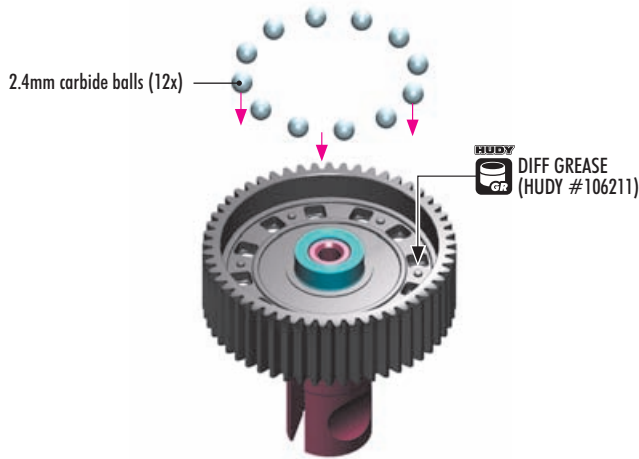

**#930220**  
CERAMIC BALL 2.4MM (12)  
OPTION



941014  
BB 10x15x4

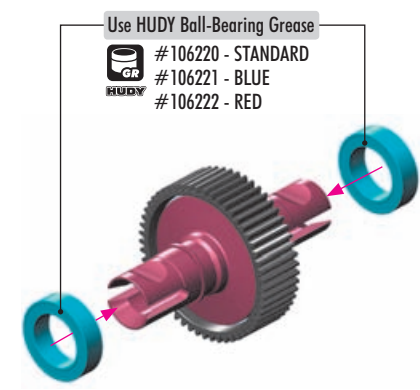
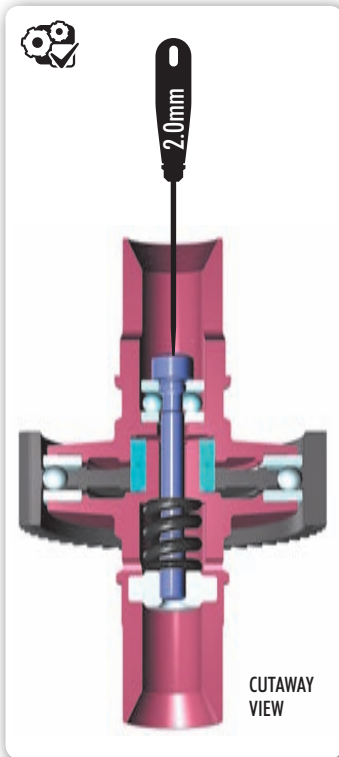
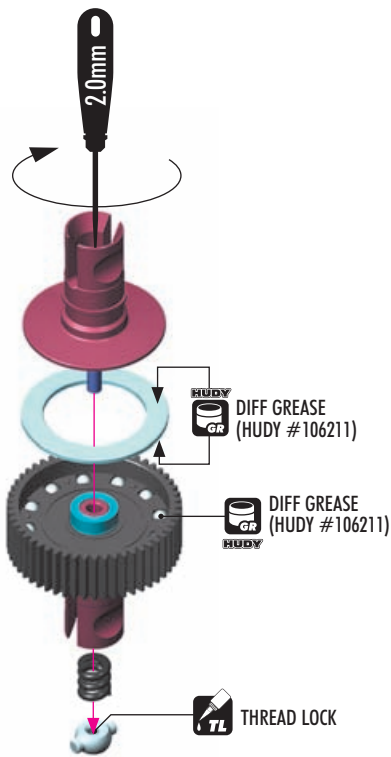



BEFORE RACING, follow these steps to properly break in the differential.

1

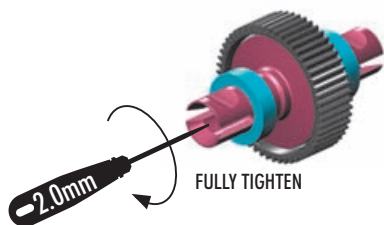

2 Loosen the adjustment screw 1/2 turn (180° CCW).

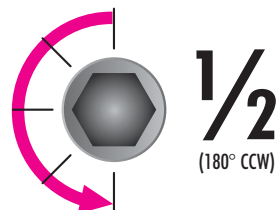
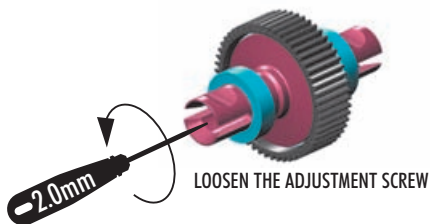

3

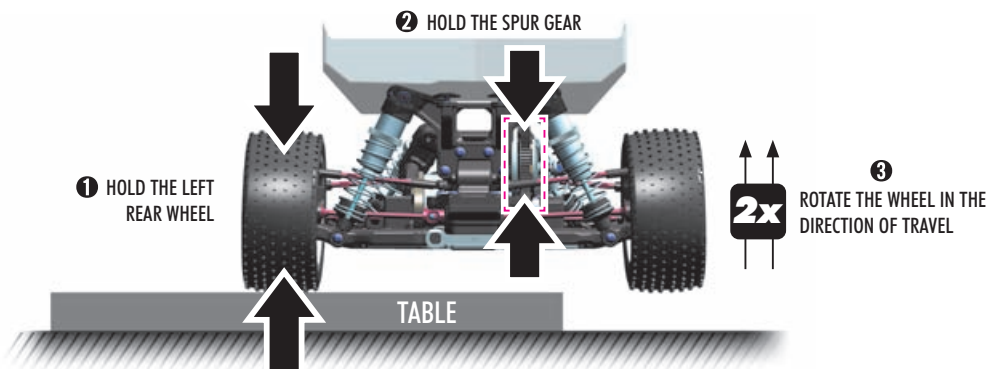

4

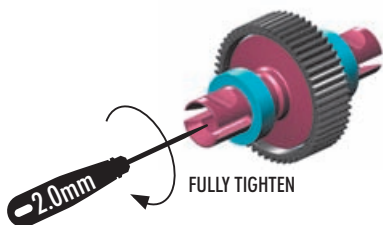

5 LOOSEN THE ADJUSTMENT SCREW 1/8 TURN (45° CCW).

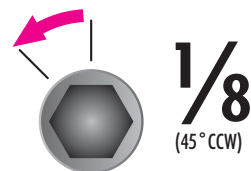
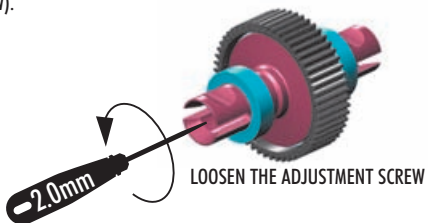

BALL DIFFERENTIAL IS NOW READY

SLIPPER CLUTCH SPUR GEARS			
OPTION	#365875	75T / 48	OPTION
	#365878	78T / 48	INCLUDED
	#365881	81T / 48	OPTION

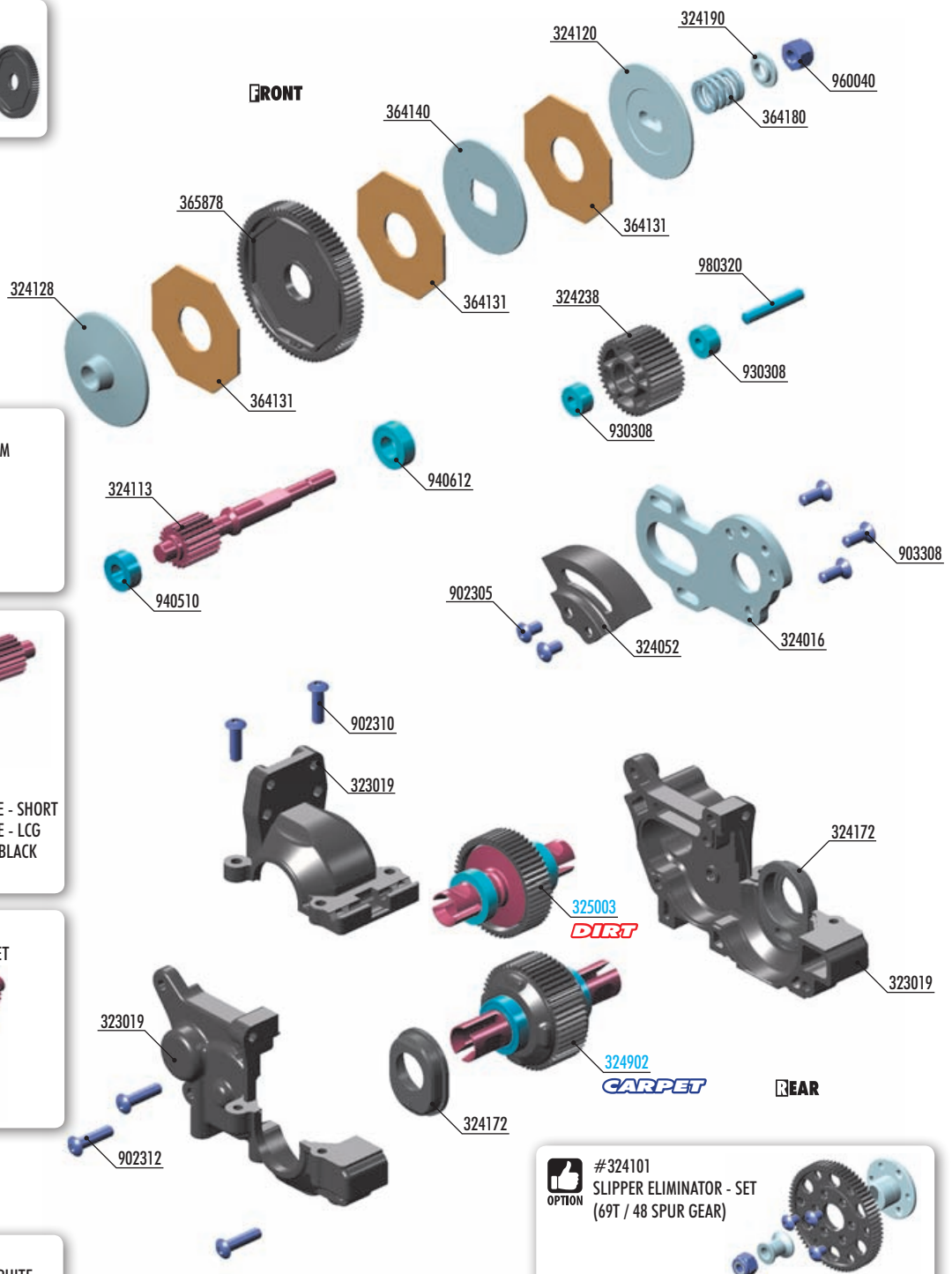
**OPTION** #324017 GRAPHITE MOTOR PLATE - LCG - 3.0MM



**OPTION** 2-PAD SLIPPER



#324114 ALU 2-PAD TOP SHAFT 20T  
 #324126 ALU 2-PAD SLIPPER CLUTCH PLATE - SHORT  
 #324129 ALU 2-PAD SLIPPER CLUTCH PLATE - LCG  
 #364181 SLIPPER CLUTCH SPRING C=45 - BLACK  
 #324191 STEEL SLIPPER CLUTCH NUT

**OPTION** #324102 SOLID AXLE - LCG - LIGHTWEIGHT - SET



**OPTION** #323019-G FRONT MOTOR GEAR BOX - LCG - GRAPHITE



**OPTION** #980320-T Titan Pin 3x20 (2)



**OPTION** #324101 SLIPPER ELIMINATOR - SET (69T / 48 SPUR GEAR)



**OPTION** #325872 SLIPPER ELIMINATOR SPUR GEAR 72T / 48



**BAG**

02

- 323019 COMPOSITE FRONT MOTOR GEAR BOX - LCG - SET
- 324016 ALU MOTOR PLATE - LCG - SWISS 7075 T6 (3MM)
- 324052 COMPOSITE GEAR COVER - LCG
- 324113 ALU 3-PAD TOP SHAFT 20T - LCG - SWISS 7075 T6 - HARD COATED
- 324120 ALU 3-PAD SLIPPER CLUTCH PLATE - SWISS 7075 T6
- 324128 ALU 3-PAD SLIPPER CLUTCH PLATE WITH ADAPTER - LCG
- 324172 COMPOSITE ADJUSTMENT BALL-BEARING HUB (2)
- 324190 ALU 3-PAD SLIPPER CLUTCH SHIM
- 324238 COMPOSITE GEAR 38T - LCG - GRAPHITE
- 364131 SLIPPER CLUTCH PAD SLS - SOFT (3)
- 364140 ALU 3-PAD SLIPPER CLUTCH PLATE DISC - 7075 T6
- 364180 SLIPPER CLUTCH SPRING C=30 - BLACK
- 365878 COMPOSITE 3-PAD SLIPPER CLUTCH SPUR GEAR 78T / 48

- 902305 HEX SCREW SH M3x5 (10)
- 902310 HEX SCREW SH M3x10 (10)
- 902312 HEX SCREW SH M3x12 (10)
- 903308 HEX SCREW SFH M3x8 (10)
- 930308 BALL-BEARING 3x8x4 STEEL SEALED - OIL (2)
- 940510 BALL-BEARING 5x10x4 RUBBER SEALED - OIL (2)
- 940612 BALL-BEARING 6x12x4 RUBBER SEALED - OIL (2)
- 960040 NUT M4 (10)
- 980320 PIN 3x20 (10)
- 324902 GEAR DIFFERENTIAL - LCG - SET
- 325003 BALL ADJUSTABLE DIFFERENTIAL - LCG - SET - HUDY SPRING STEEL™

# 2. REAR TRANSMISSION **CARPET** **DIRT**

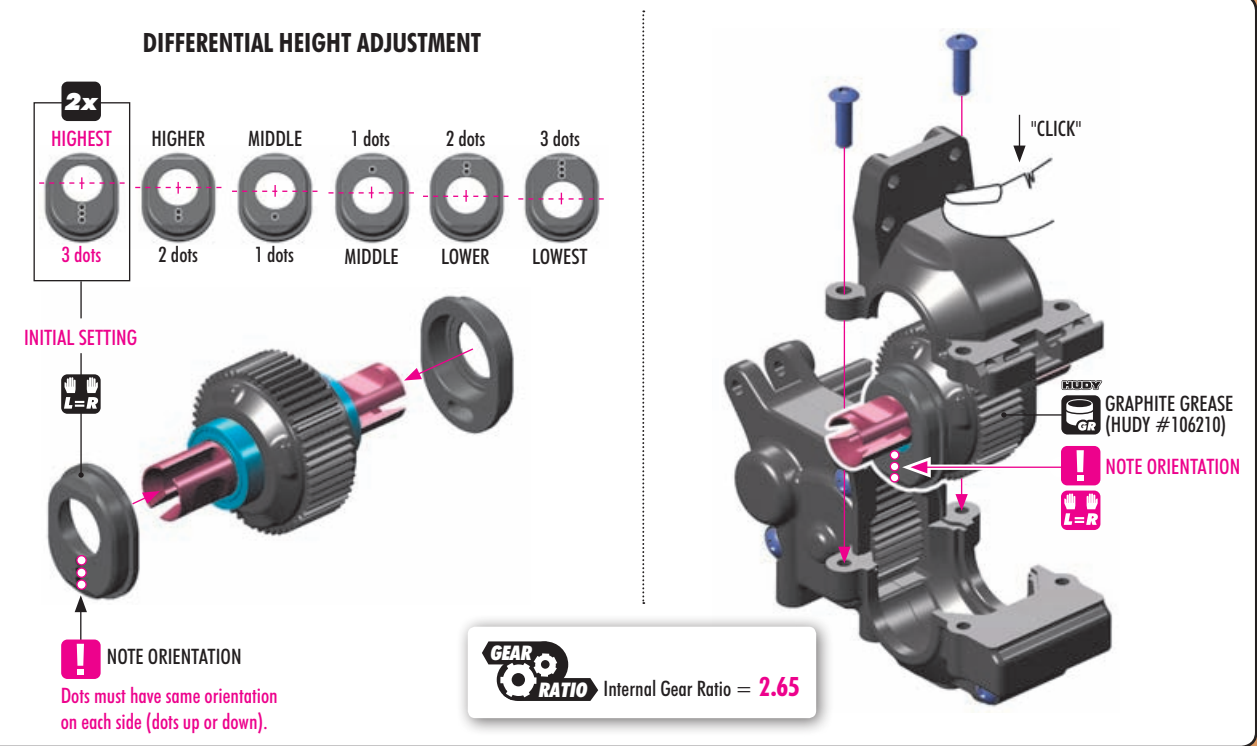
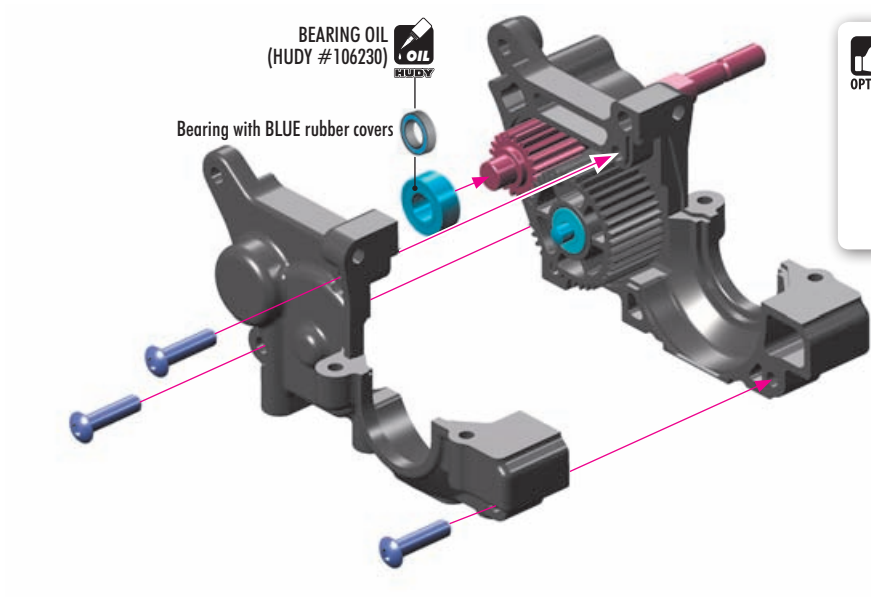
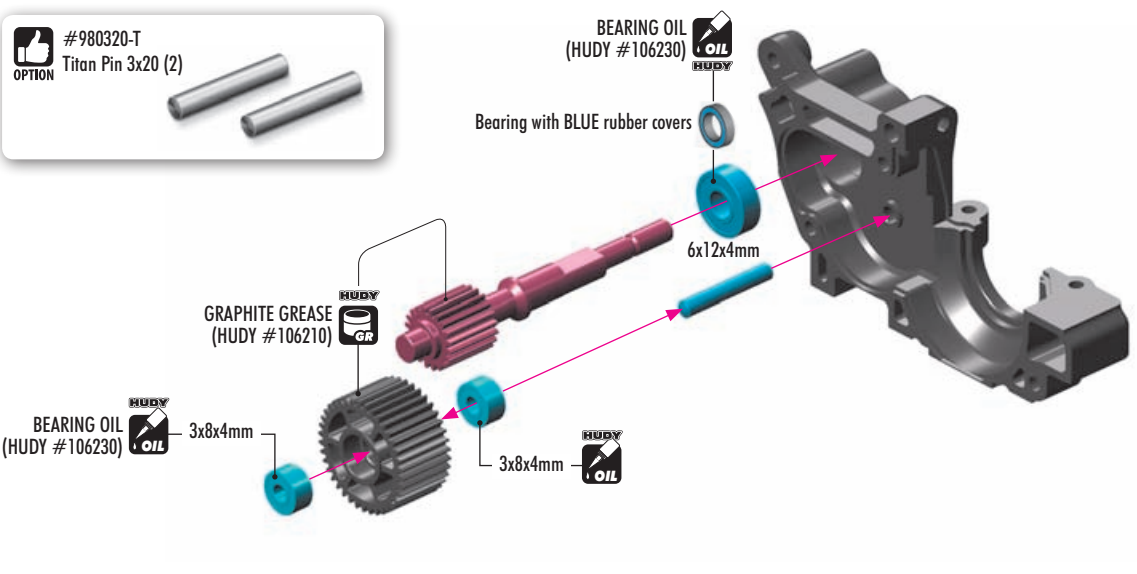
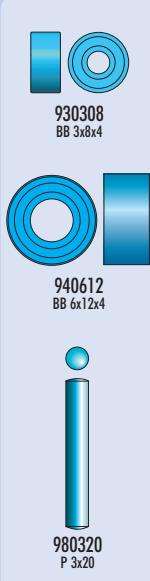

# 2. REAR TRANSMISSION **CARPET** **DIRT**

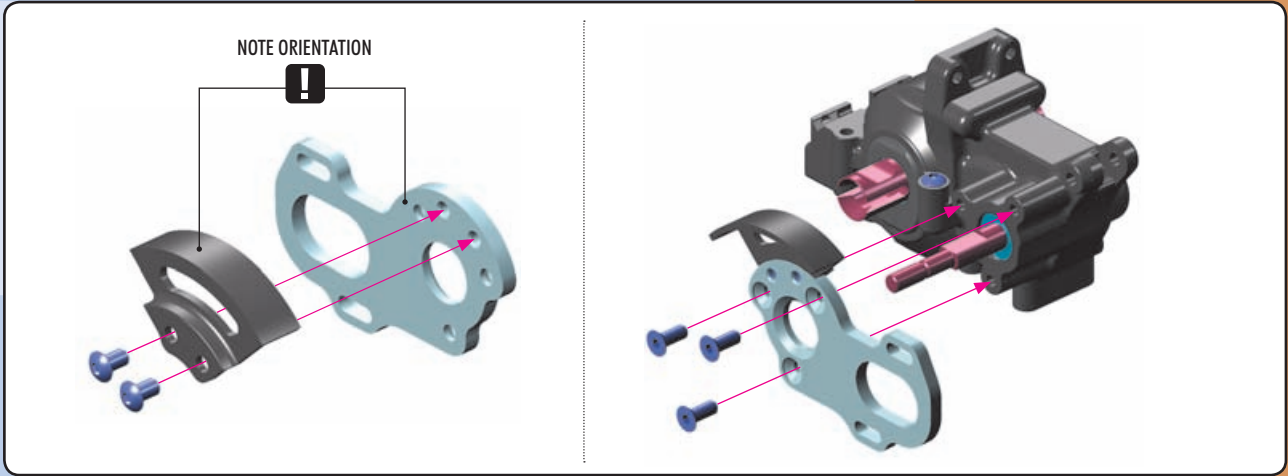

**#324102**  
SOLID AXLE - LCG - LIGHTWEIGHT - SET  
OPTION



**SLIPPER CLUTCH SPUR GEARS**

#365875	75T / 48	OPTION
#365878	78T / 48	INCLUDED
#365881	81T / 48	OPTION

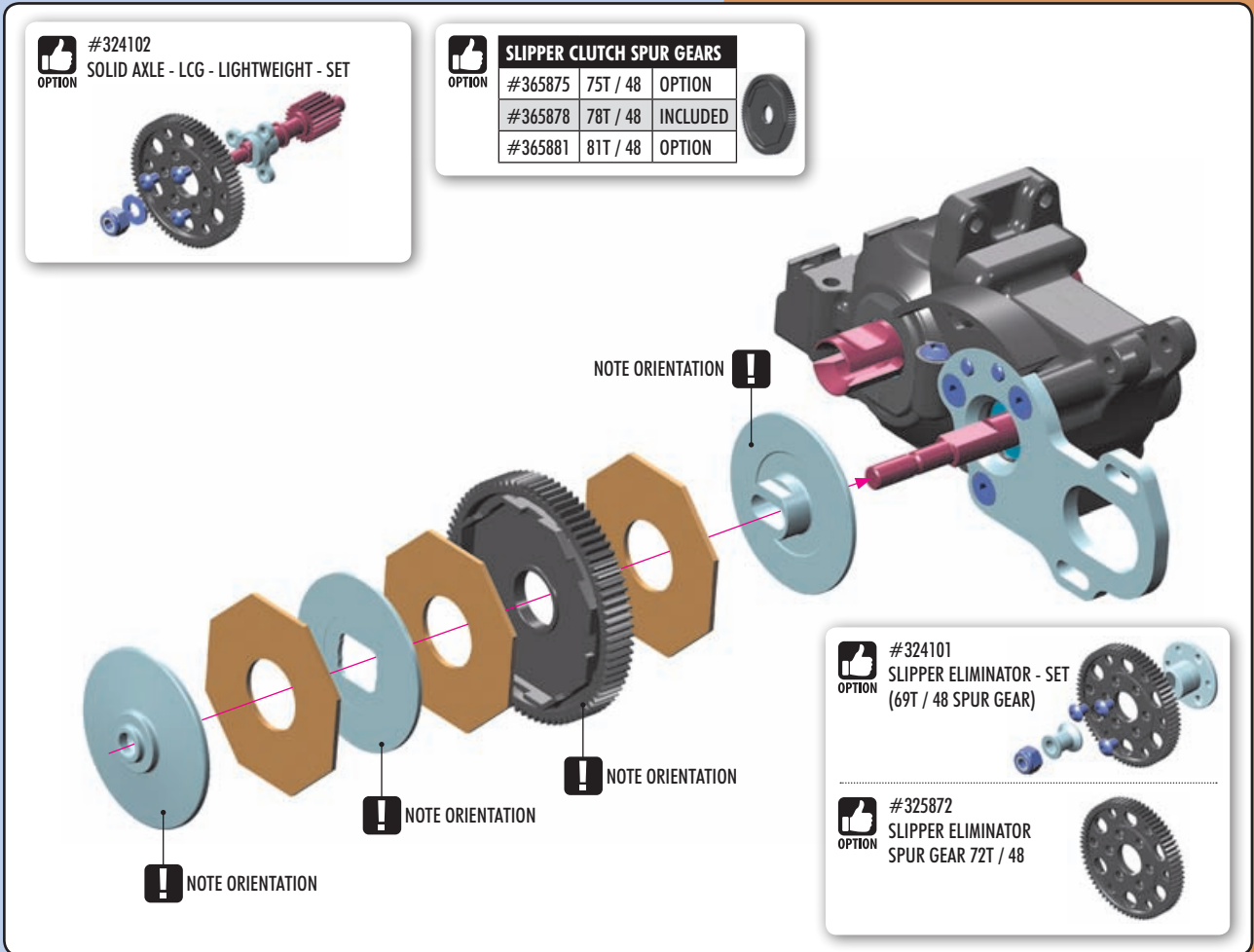

**#324101**  
SLIPPER ELIMINATOR - SET  
(69T / 48 SPUR GEAR)  
OPTION



**#325872**  
SLIPPER ELIMINATOR  
SPUR GEAR 72T / 48  
OPTION

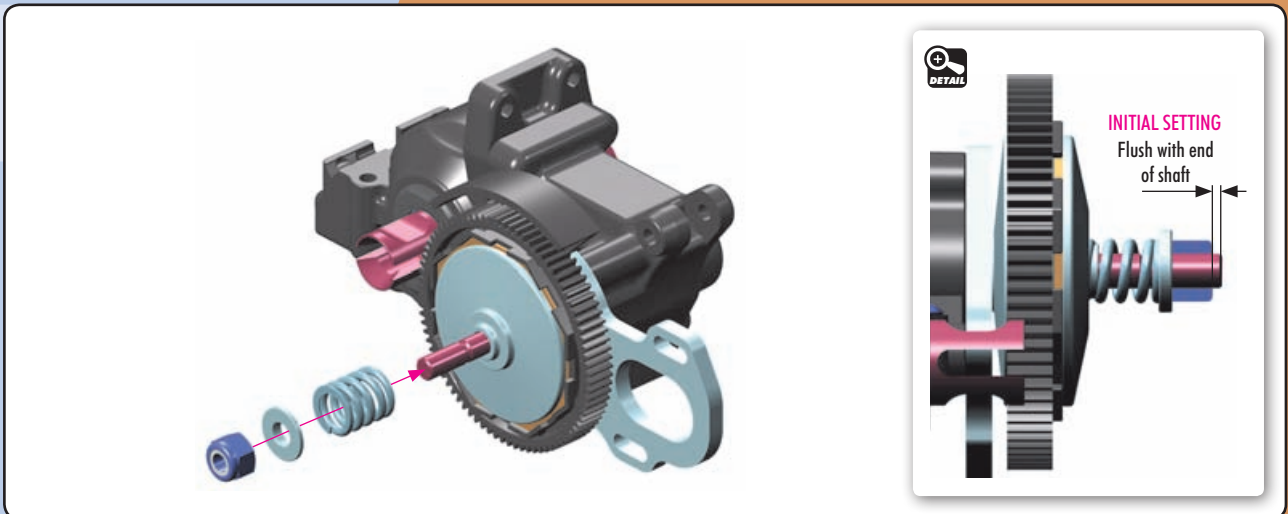





306219  
SHIM 3x6x2



903308  
SFH M3x8

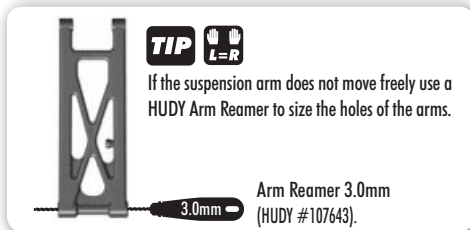
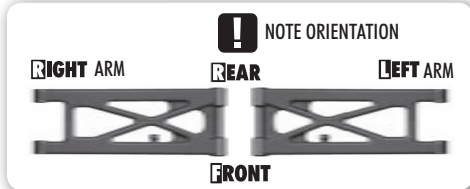
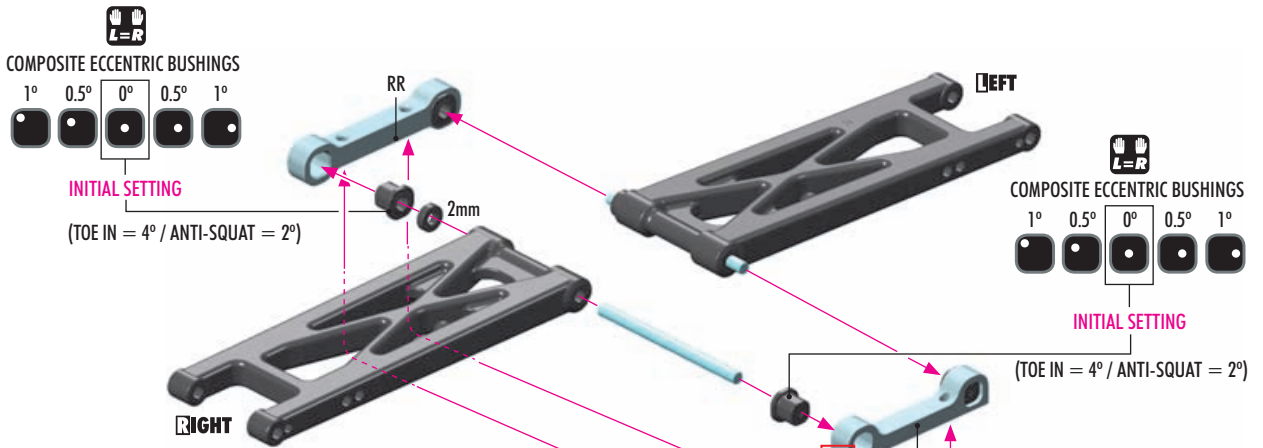

**ECCENTRIC BUSHINGS HAVE TWO DIFFERENT OFFSETS FROM THE CENTER.**

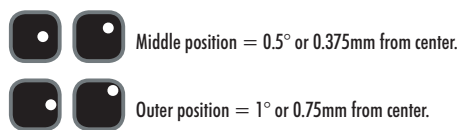

OPTION	REAR SUSPENSION ARMS		
#323112-M	MEDIUM	INCLUDED	
#323112-H	HARD	OPTION	
#323112-G	GRAPHITE	OPTION	

MEDIUM - For very-low & low traction.  
 HARD - For medium & high traction.  
 GRAPHITE - For high & very-high traction.



**SET-UP BOOK**  
TOE-IN  
ANTI-SQUAT  
ROLL CENTER  
TRACK-WIDTH

The XRAY rear alu lower suspension holders provide great range of adjustment for the rear suspension. Using different combinations of eccentric bushings, fine adjustment of rear anti-squat, rear toe-in, rear roll center, and rear track-width can be obtained. For more information about the influence of rear anti-squat, rear toe-in, rear roll center and rear track width on car handling, please refer to HUDY Set-up Book (#209100).

ANTI-SQUAT			(°)
RR	RF		
0	0		= 2°
0	0		= 3°
0	0		= 1°
0	0		= 3°
0	0		= 2°
0	0		= 4°
0	0		= 1°
0	0		= 2°
0	0		= 0°

ROLL CENTER			(mm)
RR	RF		
0	0		= +0.75mm
0	0		= 0mm
0	0		= -0.75mm

TRACK-WIDTH			(mm)
RR	RF		
0	0		= +1.5mm
0	0		= 0mm
0	0		= -1.5mm

TOE-IN			(°)
RR	RF		
0	0		= 3°
0	0		= 4°
0	0		= 2°
0	0		= 2°
0	0		= 3°
0	0		= 1°
0	0		= 4°
0	0		= 5°
0	0		= 3°

The track-width is directly influenced by the size of the wheels and tires used.

The tables describe the amounts of adjustment using the center and outside positions of the eccentric bushings. The middle position eccentric bushings allow for finer adjustment increments.

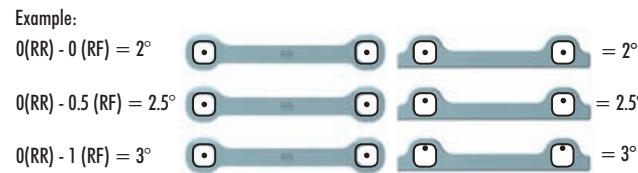

# 3. REAR SUSPENSION **CARPET** **DIRT**

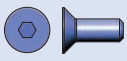

903308  
SFH M3x8

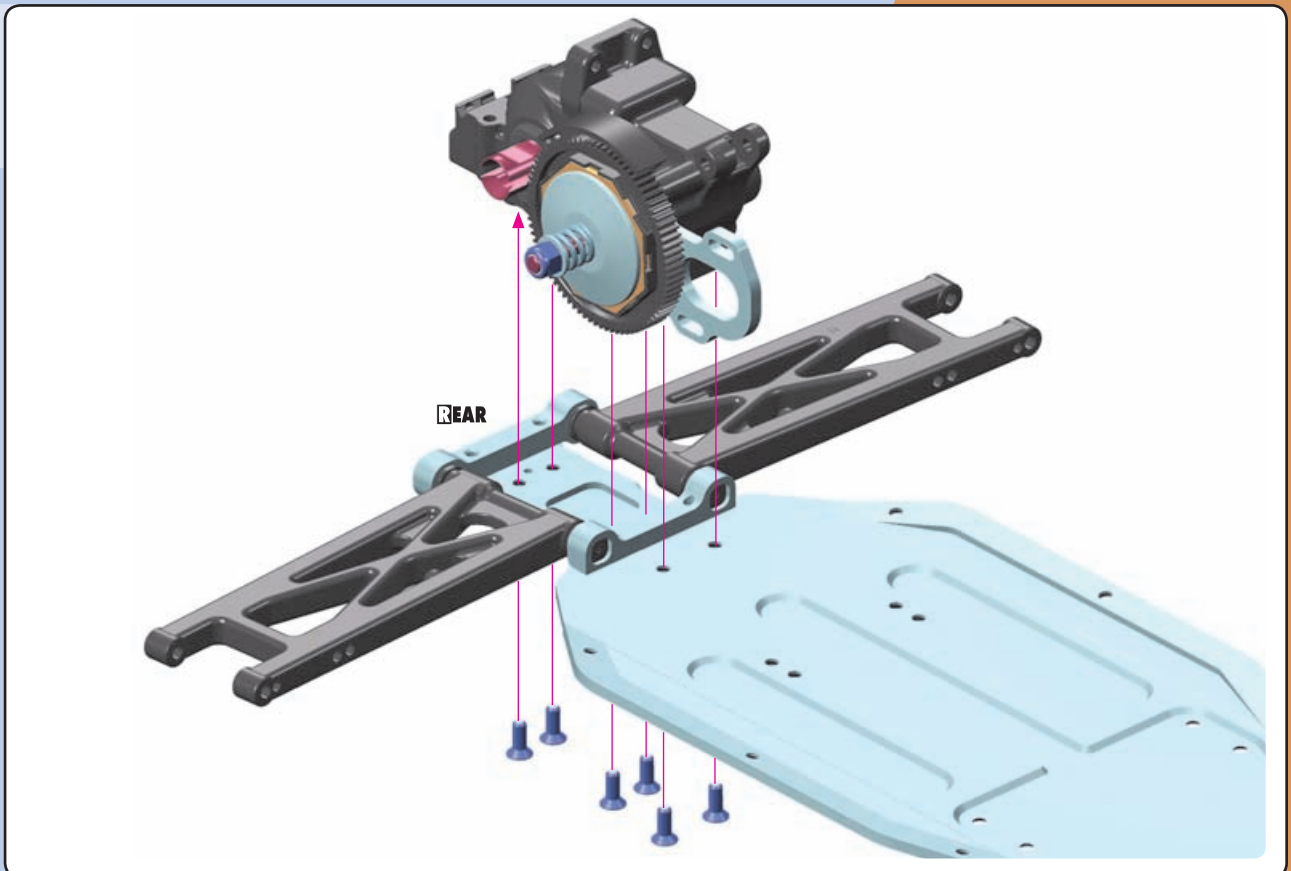

309319  
SHIM 3x7x3



309319  
SHIM 3x7x6

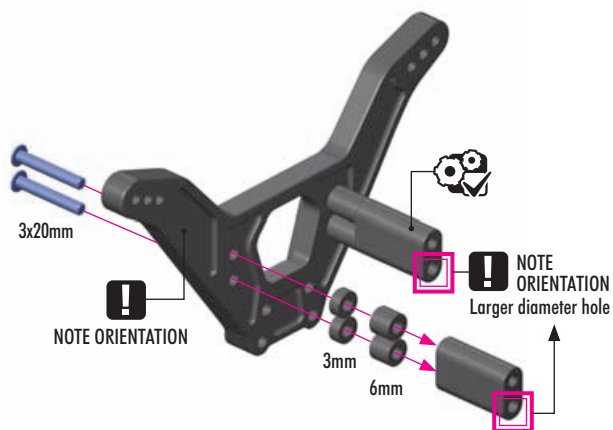

#323091  
GRAPHITE SHOCK TOWER REAR - 4.0MM



902316  
SH M3x16



902325  
SH M3x25

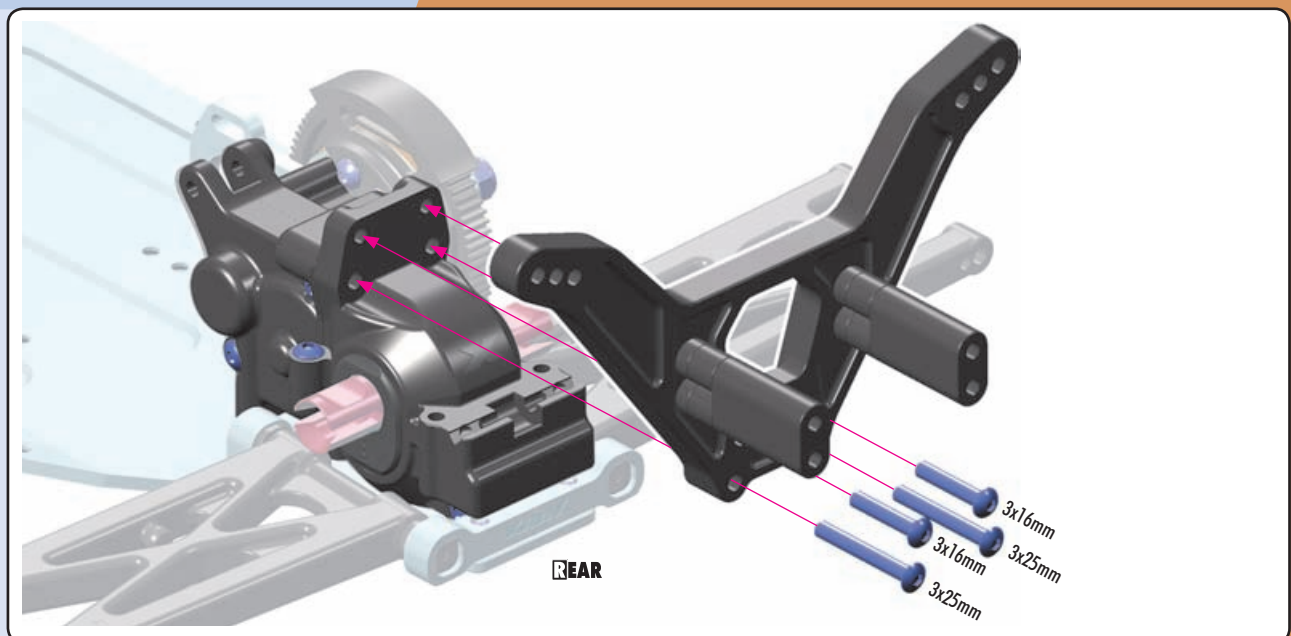



# 3. REAR DRIVETRAIN

# CARPET DIRT

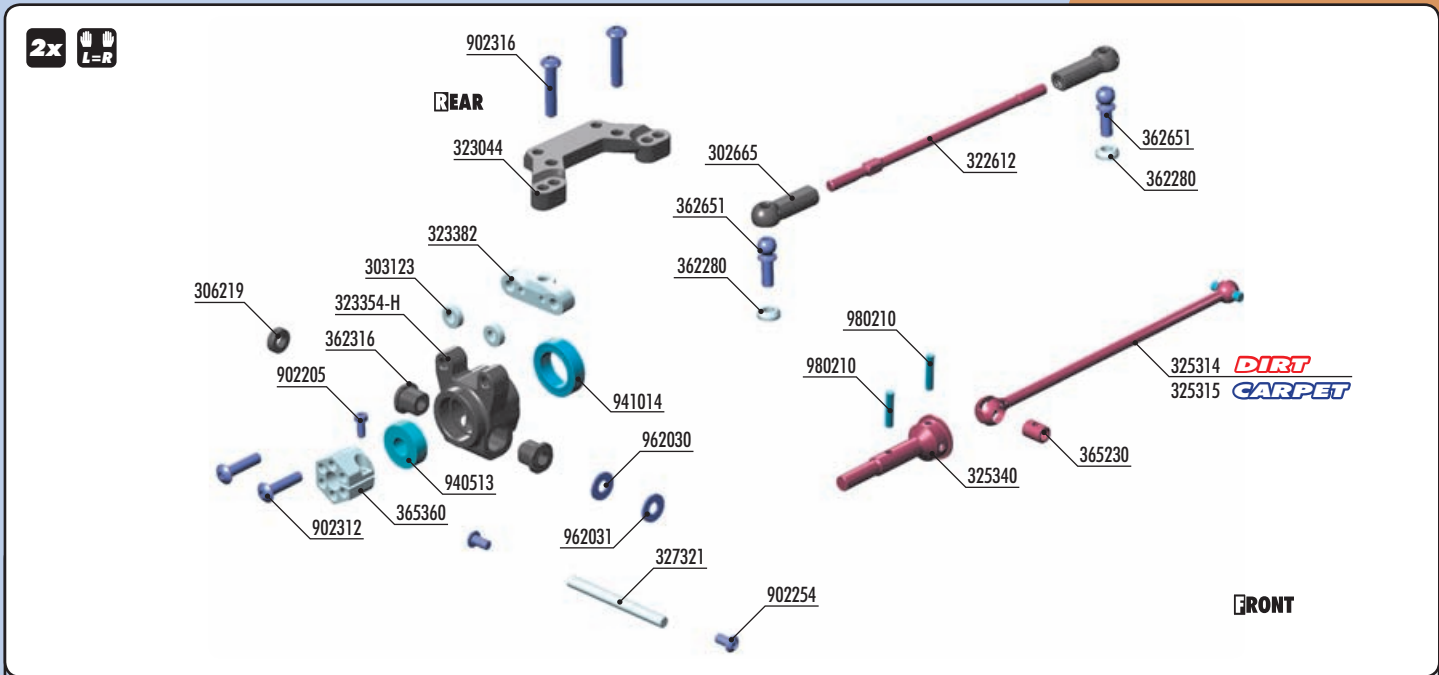

**BAG**

**03**

- |          |  |        |   |
|----------|--|--------|---|
| 302665   | COMPOSITE BALL JOINT 4.9MM - CLOSED WITH HOLE (4)            | 362651 | BALL END 4.9MM WITH THREAD 8MM (2)              |
| 303123   | ALU SHIM 3x6x2.0MM (10)                                      | 365230 | DRIVE SHAFT COUPLING - HUDY SPRING STEEL™       |
| 306219   | COMPOSITE SET OF SERVO SHIMS (4)                             | 365360 | ALU WHEEL HUB 12MM - OFFSET "+3.0MM" (2)        |
| 322612   | ADJUSTABLE TURNBUCKLE 75MM M3 L/R - HUDY SPRING STEEL™ (2)   | 902205 | HEX SCREW SH M2x5 (10)                          |
| 323044   | COMPOSITE REAR ROLL CENTER HOLDER                            | 902254 | HEX SCREW SH M2.5x4 (10)                        |
| 323354-H | COMPOSITE UPRIGHT REAR - HARD                                | 902312 | HEX SCREW SH M3x12 (10)                         |
| 323382   | ALU REAR HUB PLATE FOR MULTI ADJ. UPRIGHT - 1-HOLE - 7075 T6 | 902316 | HEX SCREW SH M3x16 (10)                         |
| 325314   | DRIVE SHAFT 96MM WITH 2.5MM PIN - HUDY SPRING STEEL™         | 940513 | BALL-BEARING 5x12x4 RUBBER SEALED - GREASE (2)  |
| 325315   | DRIVE SHAFT 94MM WITH 2.5MM PIN - HUDY SPRING STEEL™         | 941014 | BALL-BEARING 10x15x4 RUBBER SEALED - GREASE (2) |
| 325340   | REAR DRIVE AXLE LB - HUDY SPRING STEEL™                      | 962030 | WASHER S 3x6x0.3 (10)                           |
| 327321   | REAR ARM PIVOT PIN (2)                                       | 962031 | WASHER S 3x6x0.1 (10)                           |
| 362280   | ALU CONICAL SHIM 3x6x2.0MM (10)                              | 980210 | PIN 2x9.8 (10)                                  |
| 362316   | ECCENTRIC BUSHING SET - OPEN (2)                             |        |   |

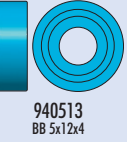
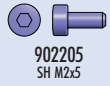

**2x** **L=R**

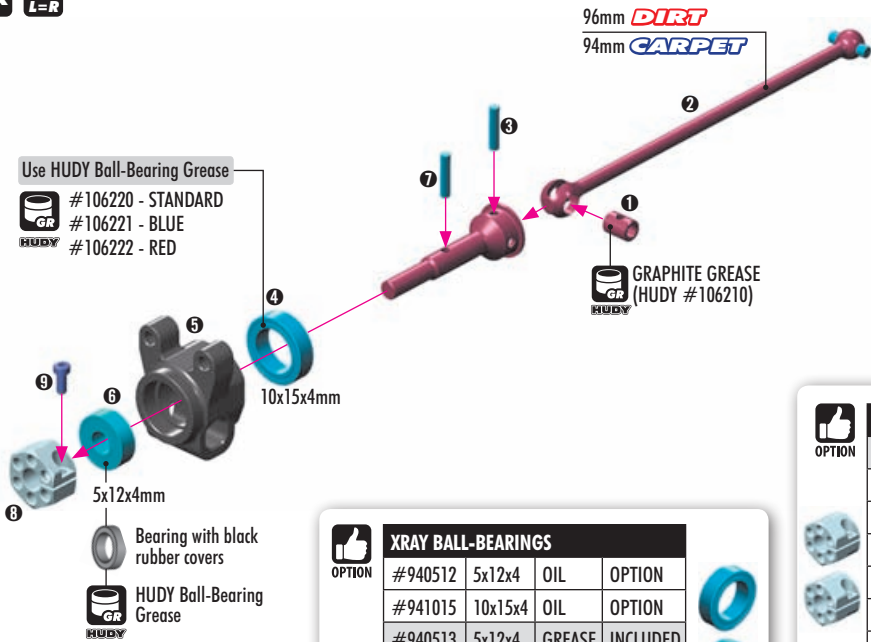

**OPTION**

XRAY BALL-BEARINGS			
#940512	5x12x4	OIL	OPTION
#941015	10x15x4	OIL	OPTION
#940513	5x12x4	GREASE	INCLUDED
#941014	10x15x4	GREASE	INCLUDED

**OPTION**

REAR UPRIGHTS			
#323354-H	HARD	INCLUDED	
#323354-G	GRAPHITE	OPTION	
#323355	ALU HIGH	OPTION	
#323356	ALU LOW	OPTION	



**OPTION**

WHEEL HEX HUBS 12MM			
#365360	+4.5mm	6 SLOTS	INCLUDED
#365359	+3.75mm	5 SLOTS	OPTION
#365358	+3.0mm	4 SLOTS	OPTION
#365357	+2.25mm	3 SLOTS	OPTION
#365356	+1.5mm	2 SLOTS	OPTION
#365355	+0.75mm	1 SLOT	OPTION
#365353	0mm	0 SLOTS	OPTION
#365354	-0.75mm	Lightw.	OPTION
#365361	-1.25mm	Lightw.	OPTION

**OPTIONAL HEX HUB EFFECTS**

Different offset hex hubs are used to increase or decrease the track-width.

**LESS OFFSET**  
Rear - more traction  
Front - more steering

**MORE OFFSET**  
Rear - less traction  
Front - less steering

# 3. REAR DRIVETRAIN **CARPET** **DIRT**



303123  
SHIM 3x6x2



902312  
SH M3x12

2x L=R

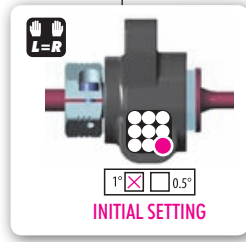
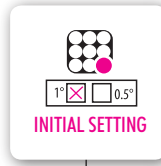

NOTE ORIENTATION  
INITIAL SETTING

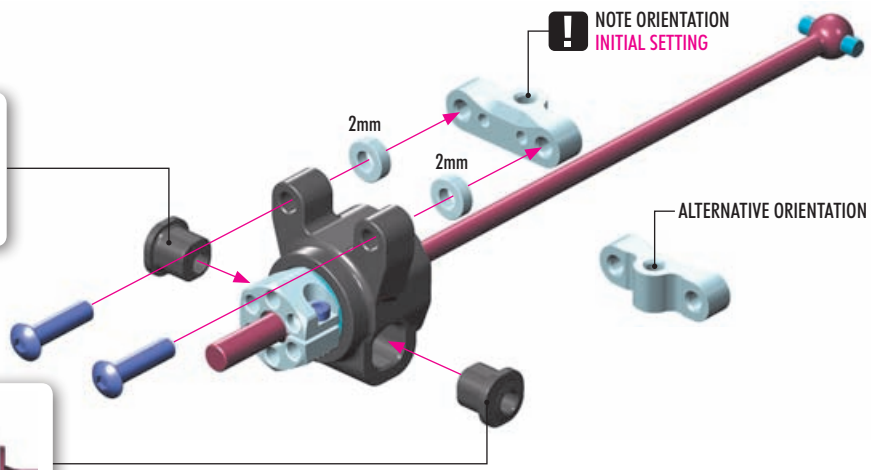

OPTION #32381  
ALU REAR HUB PLATE FOR MULTI ADJUSTABLE UPRIGHT - SWISS 7075 T6



902316  
SH M3x16

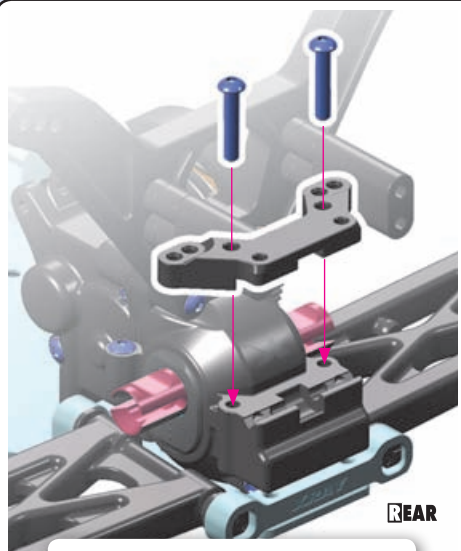

OPTION

REAR ROLL CENTER HOLDERS		
#323044	COMPOSITE	INCLUDED
#323043	ALU	OPTION
#323044-G	COMPOSITE	OPTION



OPTION #323400  
REAR ANTI-ROLL BAR 1.0mm SET

OPTION

ANTI-ROLL BARS		
#362470	1.0mm	OPTION
#362471	1.1mm	OPTION
#362472	1.2mm	OPTION
#362473	1.3mm	OPTION

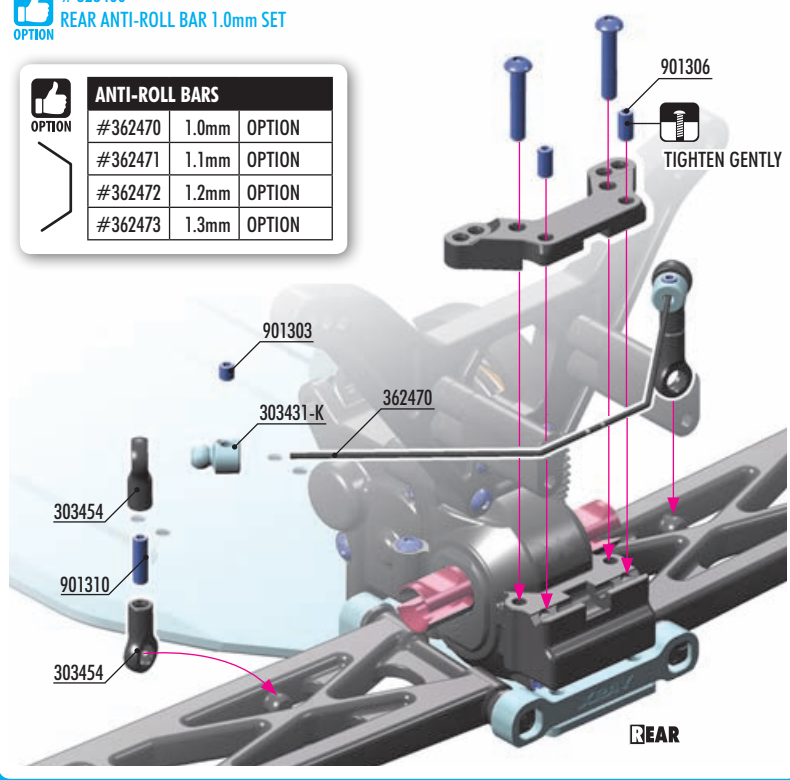

2x L=R

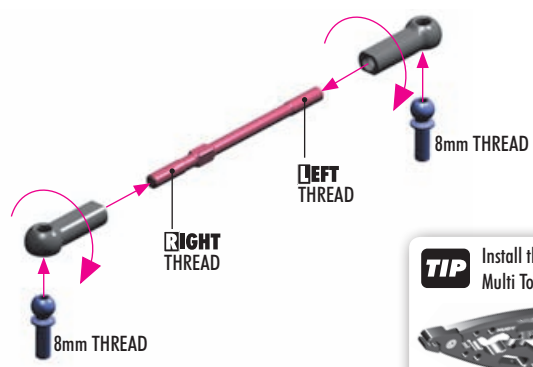

TIP Install the pivot balls with Professional Multi Tool (HUDY #183011).





306219  
SHIM 3x6x2



902254  
SH M2.5x4



962030  
S 3x6x0.3



962031  
S 3x6x0.1

2x

- 3x6x0.1mm (use for MEDIUM suspension arm)
- 3x6x0.3mm (use for HARD or GRAPHITE suspension arm)

Ensure that the rear upright moves freely.  
Check for free movement.

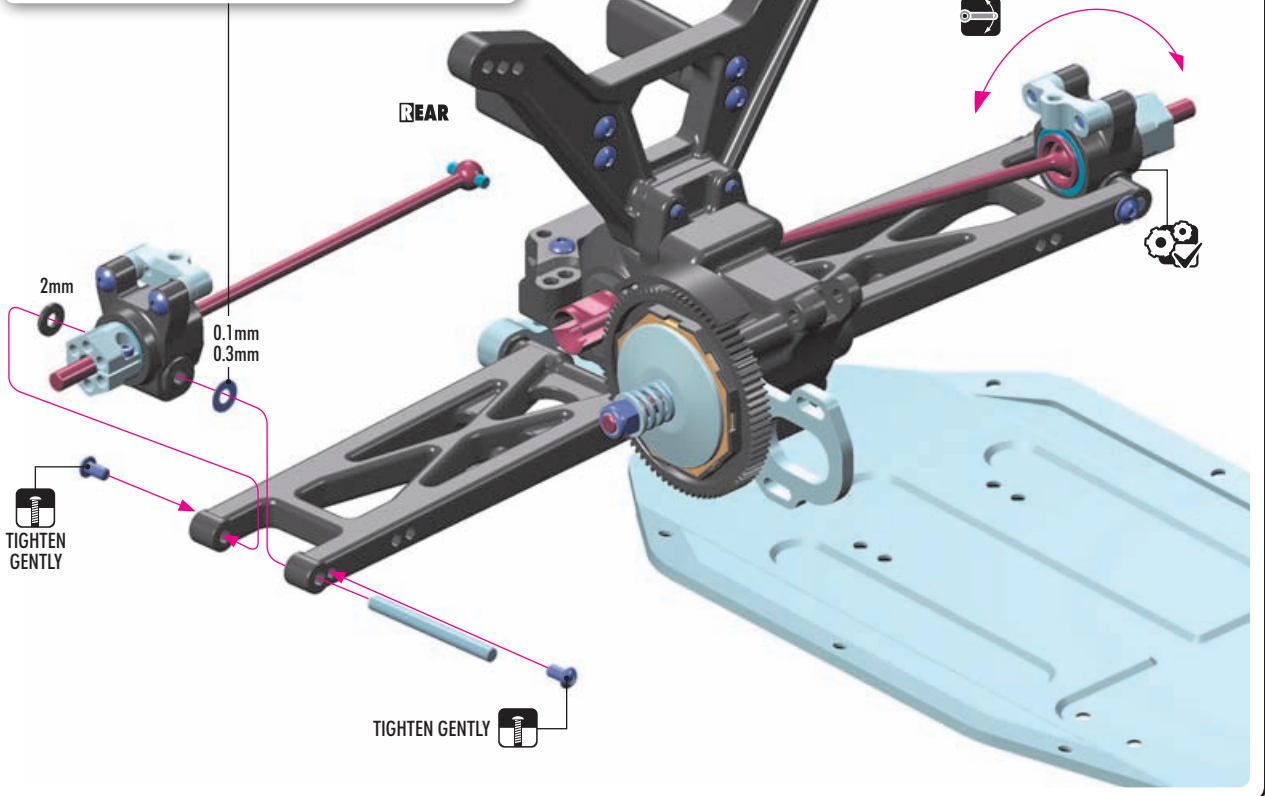

362280  
CON. SHIM 3x6x2

2x

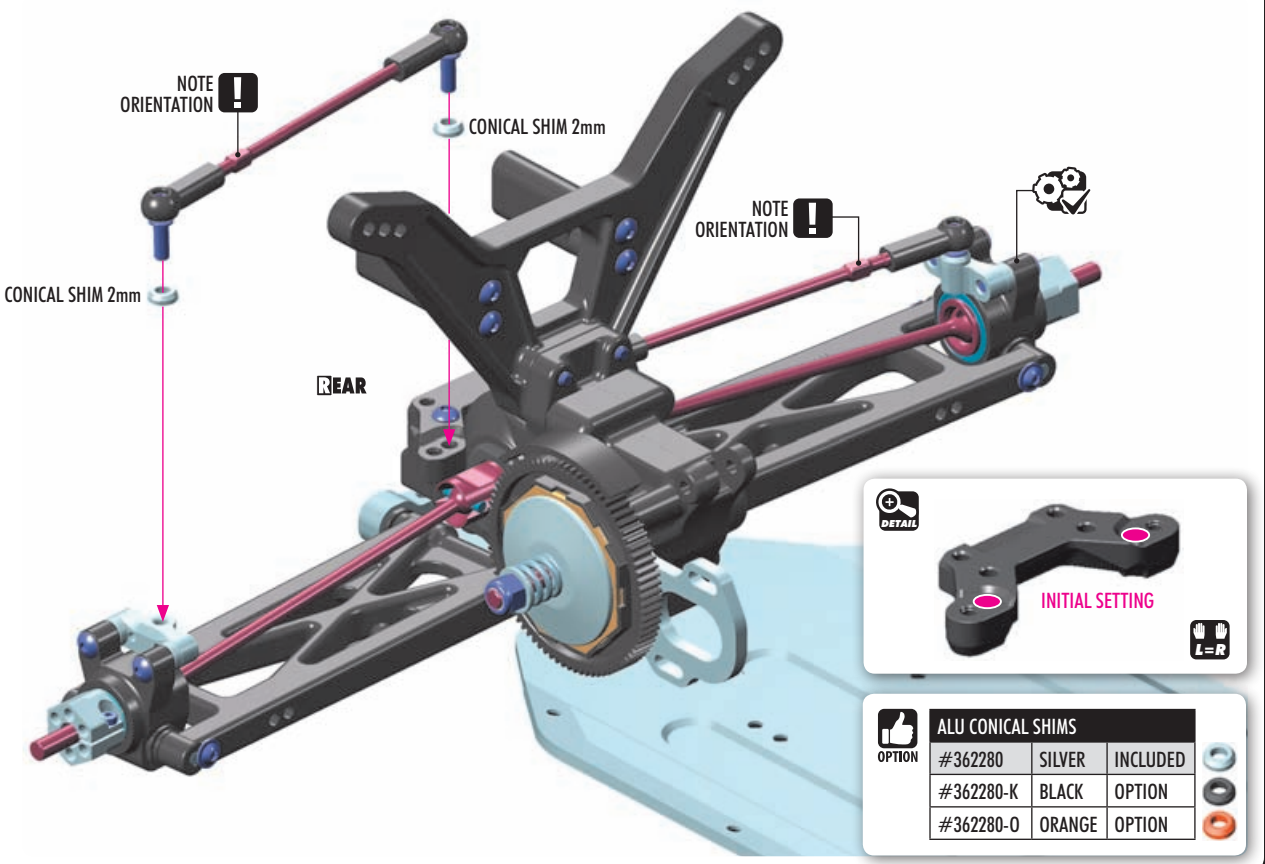



FRONT LOWER ARM MOUNTS		
#322310	ALU 26°	OPTION
#322311	COMPOSITE 26°	INCLUDED
#322312	BRASS 26°	OPTION
#322313	ALU 23°/29°	OPTION
#321211	SUSP. HOLDER BRACE 23°/29°	OPTION
#322314	BRASS 23°/29°	OPTION
#321211	SUSP. HOLDER BRACE 23°/29°	OPTION



STEERING ARMS		
#322514	HARD	INCLUDED
#322514-G	GRAPHITE	OPTION
#322513	ALU	OPTION

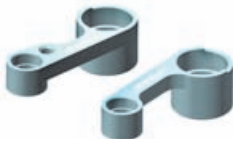

STEERING PLATES		
#322573	HARD	INCLUDED
#322573-G	GRAPHITE	OPTION
#322572	ALU	OPTION



#321250-G  
CHASSIS SIDE GUARDS FOR BENT SIDES  
OPTION CHASSIS L+R - GRAPHITE

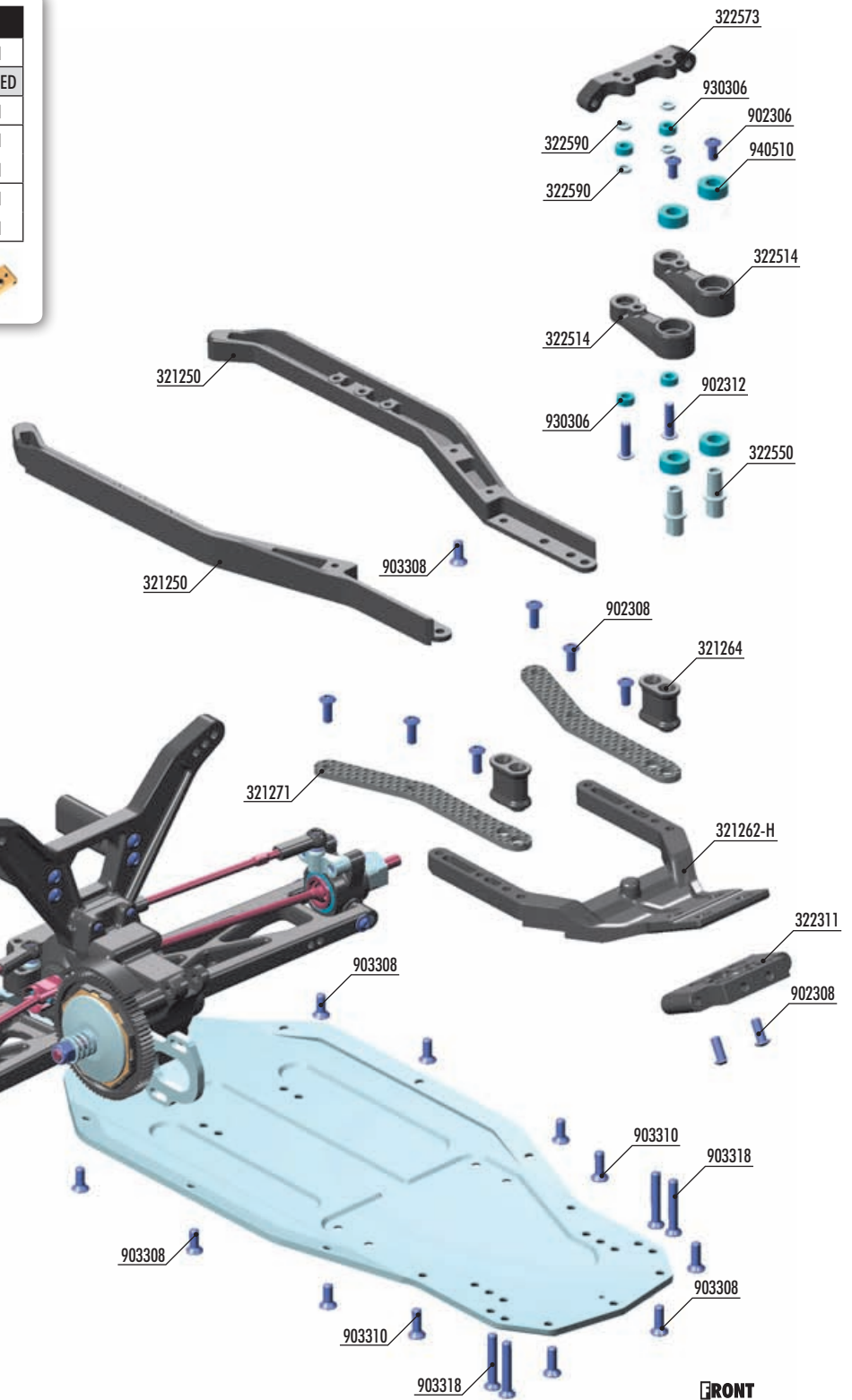

REAR

FRONT

BAG

04

- 321250 COMPOSITE CHASSIS SIDE GUARDS FOR BENT SIDES CHASSIS L+R
- 321262-H COMPOSITE CHASSIS FRONT GUARD - HARD - V2
- 321264 COMPOSITE FRONT CHASSIS SIDE BRACE - SHORT (2)
- 321271 GRAPHITE CHASSIS SIDE GUARD BRACE FOR BENT SIDES CHASSIS (2)
- 322311 COMPOSITE FRONT LOWER SUSPENSION HOLDER
- 322514 COMPOSITE STEERING ARM WITH STEERING MOUNT HOLE (2)
- 322550 ALU SERVO SAVER PIVOT SHAFT (2)
- 322573 COMPOSITE STEERING PLATE - FRONT/REAR MOUNTING POSITIONS
- 322590 ALU SHIM 3x4.7x1.0MM (10)

- 902306 HEX SCREW SH M3x6 (10)
- 902308 HEX SCREW SH M3x8 (10)
- 902312 HEX SCREW SH M3x12 (10)
- 903308 HEX SCREW SFH M3x8 (10)
- 903310 HEX SCREW SFH M3x10 (10)
- 903318 HEX SCREW SFH M3x18 (10)
- 930306 BALL-BEARING 3x6x2.5 STEEL SEALED - OIL (2)
- 940510 BALL-BEARING 5x10x4 RUBBER SEALED - OIL (2)

# 4. FRONT ASSEMBLY

# CARPET DIRT



#321250-G  
CHASSIS SIDE GUARDS FOR BENT SIDES  
OPTION  
CHASSIS L + R - GRAPHITE

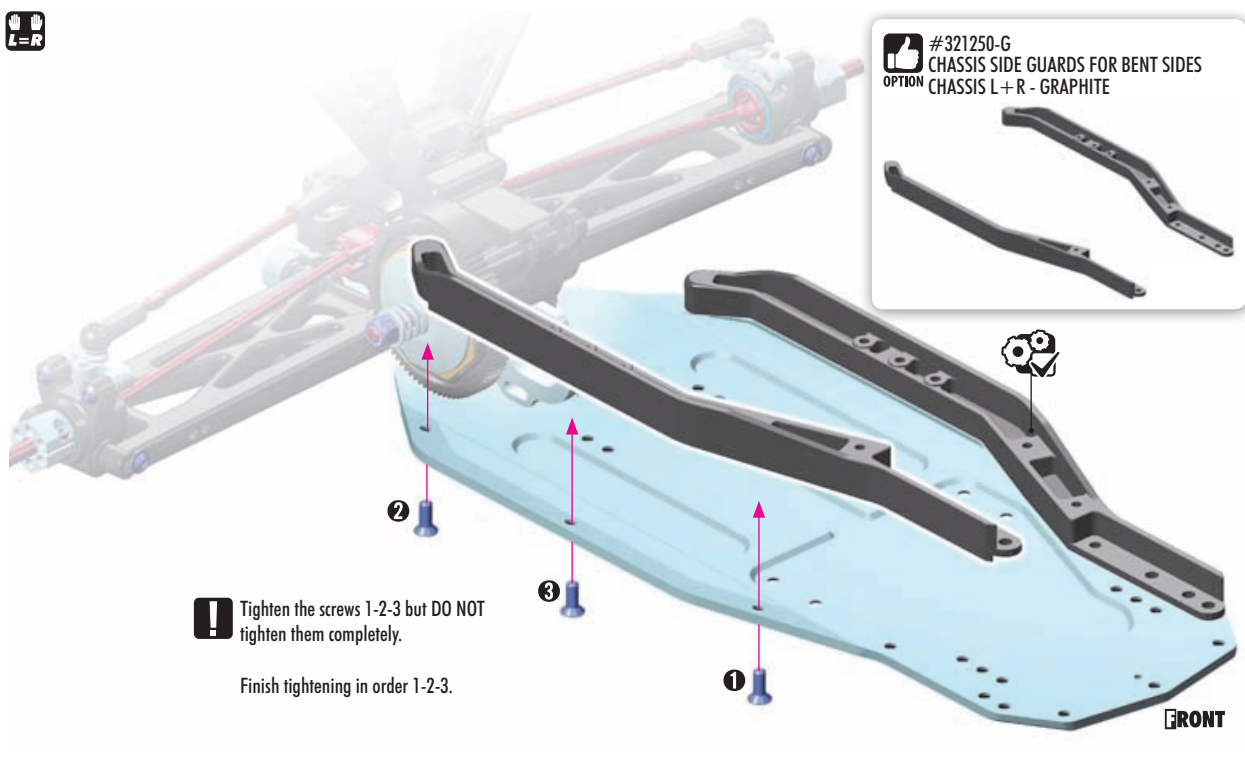

**!** Tighten the screws 1-2-3 but **DO NOT** tighten them completely.

Finish tightening in order 1-2-3.

FRONT

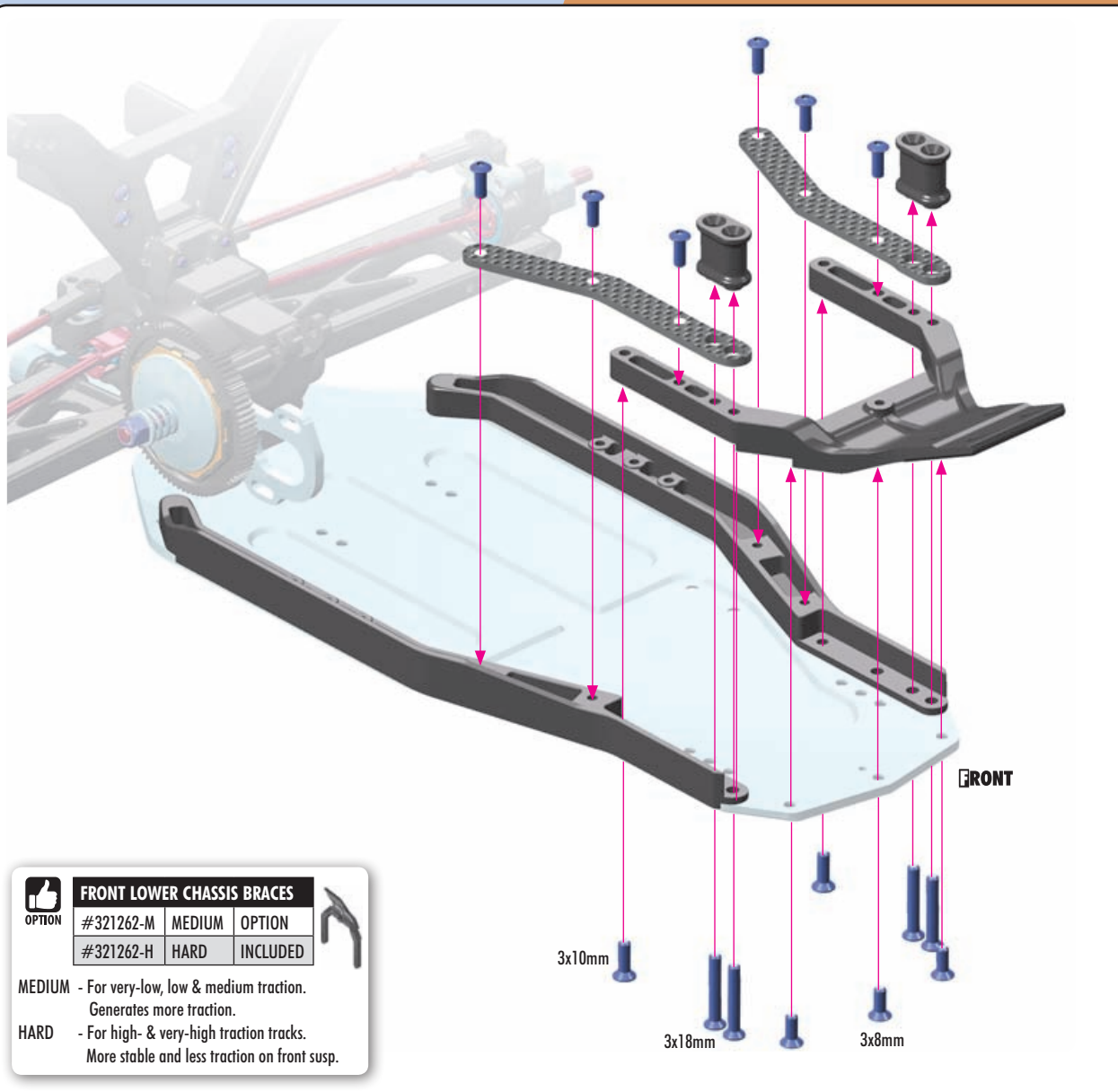

### FRONT LOWER CHASSIS BRACES

OPTION

#321262-M	MEDIUM	OPTION
#321262-H	HARD	INCLUDED

- MEDIUM** - For very-low, low & medium traction. Generates more traction.
- HARD** - For high- & very-high traction tracks. More stable and less traction on front susp.

3x10mm

3x18mm

3x8mm

FRONT



902312  
SH M3x12



930306  
BB 3x6x2.5

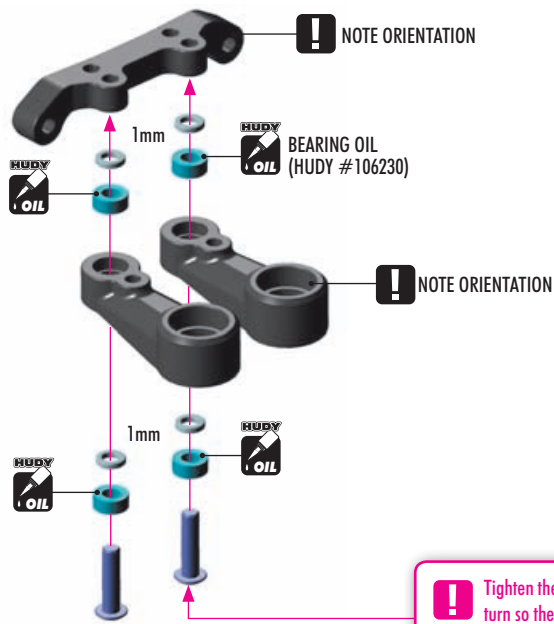

OPTION

### STEERING PLATES

#322573	HARD	INCLUDED
#322573-G	GRAPHITE	OPTION
#322572	ALU	OPTION

COMPOSITE - Easy to drive, more forgiving, less steering.  
ALU - More aggressive, more steering, more precise steering.



OPTION

### STEERING ARMS

#322514	HARD	INCLUDED
#322514-G	GRAPHITE	OPTION
#322513	ALU	OPTION

COMPOSITE - Easy to drive and more forgiving.  
ALU - More aggressive, more precise steering.

**!** Tighten the screws gently but fully, and then loosen 1/3 turn so the composite dual servo saver moves freely.

- 1 tighten fully
- 2 loosen 1/3 ccw
- 3 check moves freely

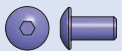

902306  
SH M3x6



940510  
BB 5x10x4

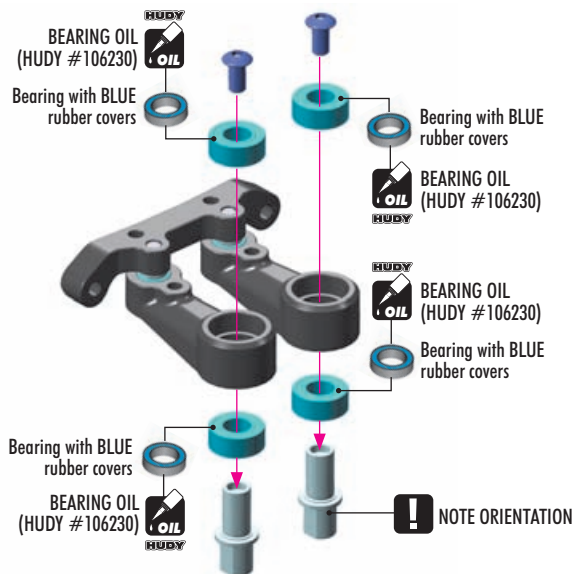

OPTION

### FRONT LOWER ARM MOUNTS

#322310	ALU 26°	OPTION
#322311	COMPOSITE 26°	INCLUDED
#322312	BRASS 26°	OPTION
#322313	ALU 23°/29°	OPTION
#321211	SUSP. HOLDER BRACE 23°/29°	OPTION
#322314	BRASS 23°/29°	OPTION
#321211	SUSP. HOLDER BRACE 23°/29°	OPTION



COMPOSITE - Generates more traction in front.  
ALU - Makes car more stable.  
BRASS - Adds more weight in front, less weight transfer.

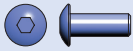

902308  
SH M3x8

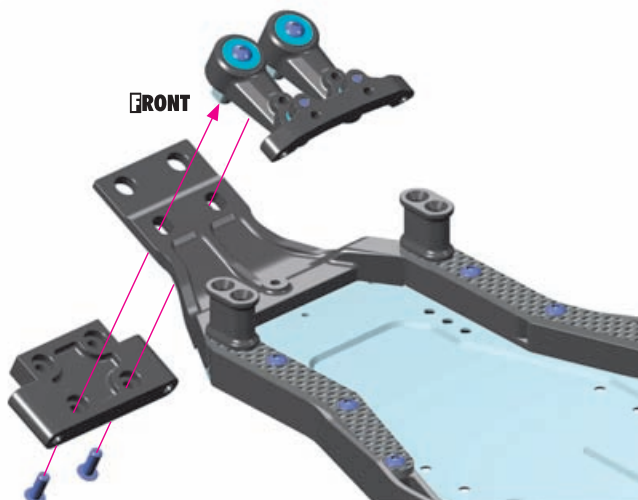

# 5. FRONT SUSPENSION **CARPET** **DIRT**

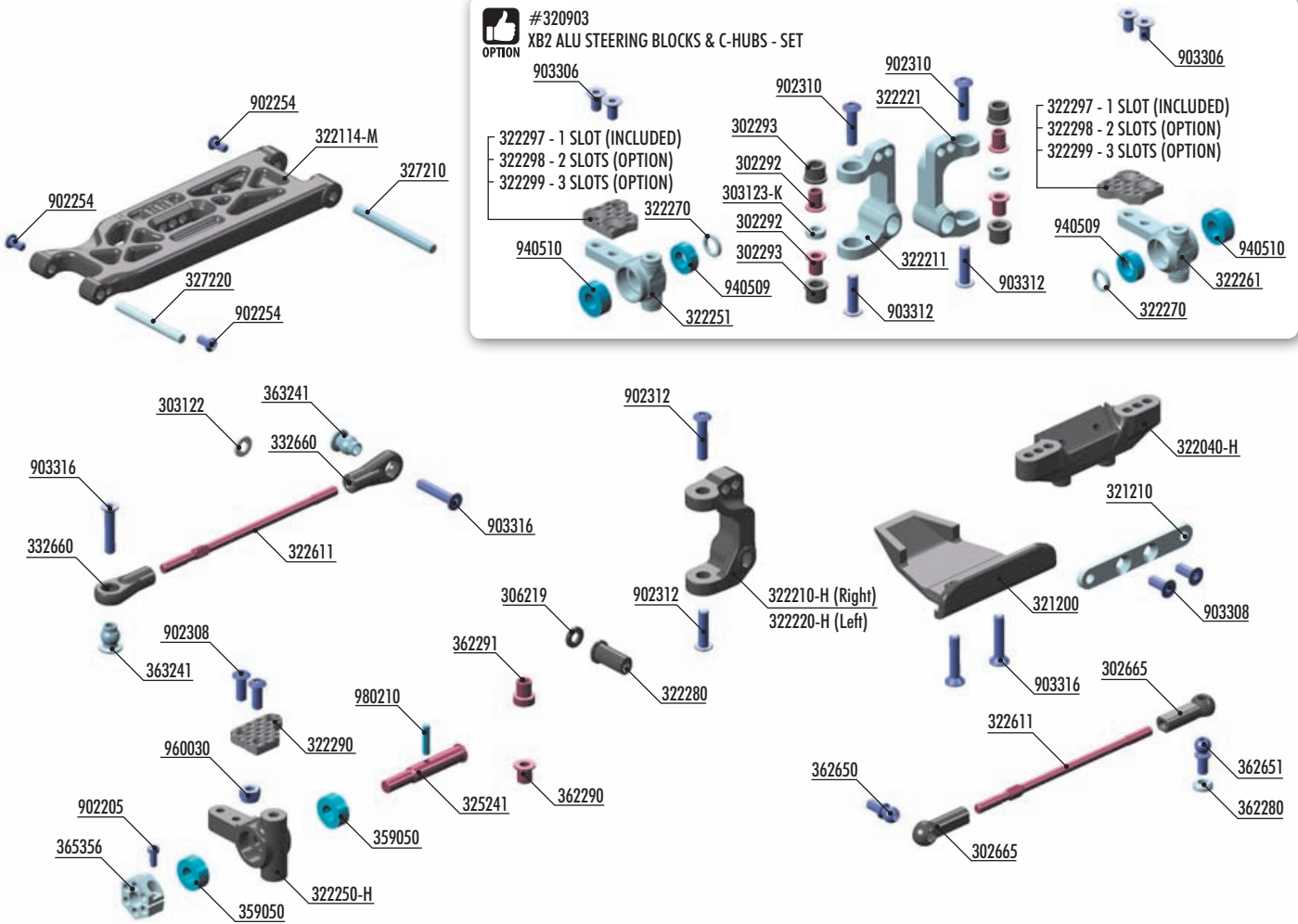

### WHEEL HEX HUBS 12MM

#365360	+4.5mm	6 SLOTS	OPTION
#365359	+3.75mm	5 SLOTS	OPTION
#365358	+3.0mm	4 SLOTS	OPTION
#365357	+2.25mm	3 SLOTS	OPTION
#365356	+1.5mm	2 SLOTS	INCLUDED
#365355	+0.75mm	1 SLOT	OPTION
#365353	0mm	0 SLOTS	OPTION
#365354	-0.75mm	Lightw.	OPTION
#365361	-1.25mm	Lightw.	OPTION



### XRAY BALL-BEARINGS

#940510	5x10x4	OIL	OPTION
#359050	5x10x4	GREASE	INCLUDED



### FRONT ROLL CENTER HOLDERS

#322040-M	MEDIUM	OPTION
#322040-H	HARD	INCLUDED



### STEERING BLOCKS

#322250-M	MEDIUM	OPTION
#322250-H	HARD	INCLUDED
#322250-G	GRAPHITE	OPTION



### STEERING BLOCK EXTENSIONS

#322290	2-SLOTS	INCLUDED
#322291	1-SLOT	OPTION
#322292	0-SLOTS	OPTION
#322293	3-SLOTS	OPTION



### C-HUBS

#322210-M	RIGHT	MEDIUM	OPTION
#322210-H	RIGHT	HARD	INCLUDED
#322210-G	RIGHT	GRAPHITE	OPTION
#322220-M	LEFT	MEDIUM	OPTION
#322220-H	LEFT	HARD	INCLUDED
#322220-G	LEFT	GRAPHITE	OPTION



### FRONT SUSPENSION ARMS

#322114-M	MEDIUM	INCLUDED
#322114-H	HARD	OPTION
#322114-G	GRAPHITE	OPTION

### BAG

05

- 302665 COMPOSITE BALL JOINT 4.9MM - CLOSED WITH HOLE (4)
- 303122 ALU SHIM 3x6x1.0MM (10)
- 306219 COMPOSITE SET OF SERVO SHIMS (4)
- 321200 COMPOSITE FRONT BUMPER
- 321210 ALU SUSPENSION HOLDER BRACE - SWISS 7075 T6 (3MM)
- 322040-H COMPOSITE FRONT ROLL-CENTER HOLDER - HARD
- 322114-M COMPOSITE SUSPENSION ARM FRONT LOWER - MEDIUM
- 322210-H COMPOSITE C-HUB 0° DEG. RIGHT - HARD
- 322220-H COMPOSITE C-HUB 0° DEG. LEFT - HARD
- 322250-H COMPOSITE STEERING BLOCK - HARD
- 322280 COMPOSITE CASTER ECCENTRIC BUSHING (2+2+2)
- 322290 GRAPHITE EXTENSION FOR STEERING BLOCK (2) - 2 SLOTS
- 322611 ADJUSTABLE TURNBUCKLE 70MM M3 L/R - HUDY SPRING STEEL™ (2)
- 325241 XT2 FRONT DRIVE AXLE - HUDY SPRING STEEL™
- 327210 FRONT SUSPENSION PIVOT PIN (2)
- 327220 FRONT ARM PIVOT PIN (2)
- 332660 COMPOSITE STEERING & SERVO BALL JOINT 5.8 MM (4+2)
- 362280 ALU CONICAL SHIM 3x6x2.0MM (10)

- 362290 STEEL STEERING BUSHING - SHORT (2)
- 362291 STEEL STEERING BUSHING - LONG (2)
- 362650 BALL END 4.9MM WITH THREAD 6MM (2)
- 362651 BALL END 4.9MM WITH THREAD 8MM (2)
- 363241 BALL UNIVERSAL 5.75MM WITH BACKSTOP (2)
- 365356 ALU WHEEL HUB 12MM - OFFSET "+1.50MM" (2)
- 359050 BALL-BEARING 5x10x4 STEEL SEALED - GREASE (2)
- 902205 HEX SCREW SH M2x5 (10)
- 902254 HEX SCREW SH M2.5x4 (10)
- 902308 HEX SCREW SH M3x8 (10)
- 902312 HEX SCREW SH M3x12 (10)
- 903308 HEX SCREW SFH M3x8 (10)
- 903316 HEX SCREW SFH M3x16 (10)
- 960030 NUT M3 (10)
- 980210 PIN 2x9.8 (10)

# 5. FRONT SUSPENSION **CARPET** **DIRT**



2x L=R

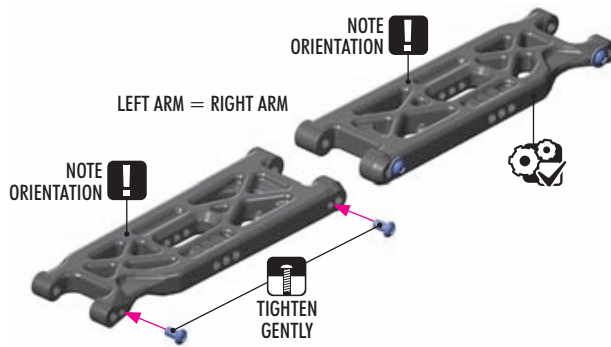

### FRONT SUSPENSION ARMS

OPTION	Part #	Material	Status
	#322114-M	MEDIUM	INCLUDED
	#322114-H	HARD	OPTION
	#322114-G	GRAPHITE	OPTION

MEDIUM - For very-low & low traction.  
 HARD - For medium & high traction.  
 GRAPHITE - For high & very-high traction.

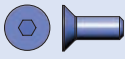

L=R

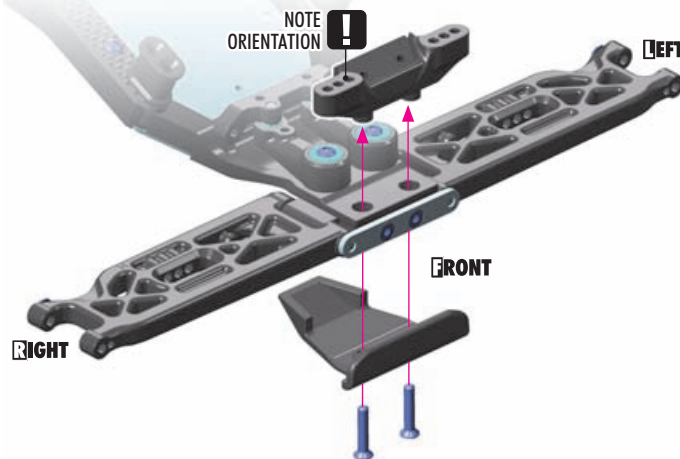
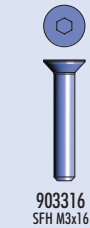
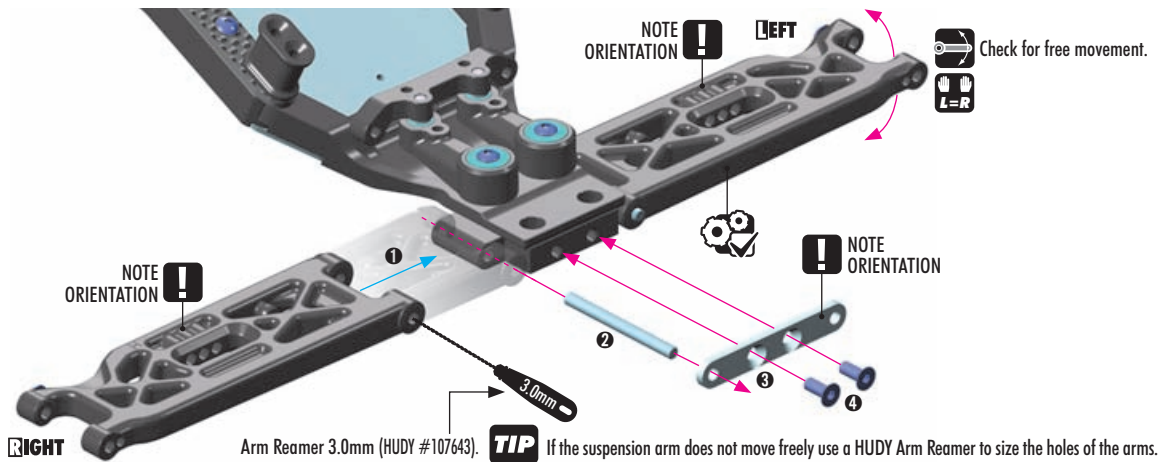

#322043  
 ALU FRONT ROLL-CENTER HOLDER FOR ANTI-ROLL BAR - WIDE



### FRONT ROLL CENTER HOLDERS

OPTION	Part #	Material	Status
	#322040-M	MEDIUM	OPTION
	#322040-H	HARD	INCLUDED

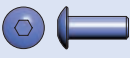

902308 SFH M3x8

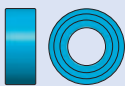

940510 BB 5x10x4

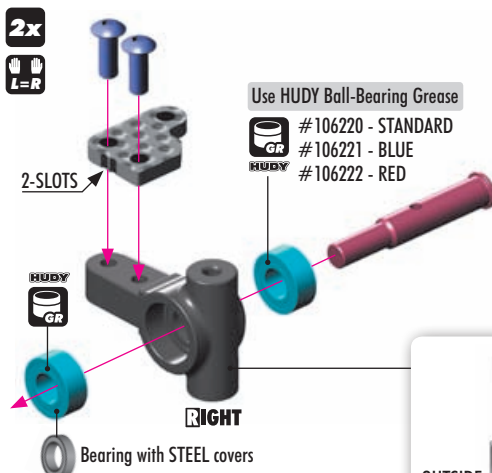

#320903 XB2 ALU STEERING BLOCKS & C-HUBS - SET



### STEERING BLOCK EXTENSIONS

OPTION	Part #	Material	Status
	#322290	2-SLOTS	INCLUDED
	#322291	1-SLOT	OPTION
	#322292	0-SLOTS	OPTION
	#322293	3-SLOTS	OPTION

3 SLOTS - Increased steering angle which increases steering in slow corners.  
 2 SLOTS - Turns outside wheels less, easier to drive, less aggressive.  
 1 SLOT - Between 2 and 0.  
 0 SLOTS - Most aggressive steering, recommended for very technical small tracks.



### STEERING BLOCKS

OPTION	Part #	Material	Status
	#322250-M	MEDIUM	OPTION
	#322250-H	HARD	INCLUDED
	#322250-G	GRAPHITE	OPTION

MEDIUM - More steering on low traction.  
 HARD - More free in corner on high grip.  
 GRAPHITE - Less stopping in corner on high traction.





# 5. FRONT SUSPENSION

# CARPET DIRT

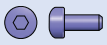

902205  
SH M2x5

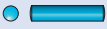

981210  
P 2x10

2x L=R

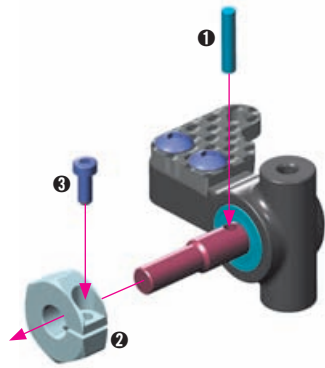

### WHEEL HEX HUBS 12MM

#365360	+4.5mm	6 SLOTS	OPTION
#365359	+3.75mm	5 SLOTS	OPTION
#365358	+3.0mm	4 SLOTS	OPTION
#365357	+2.25mm	3 SLOTS	OPTION
#365356	+1.5mm	2 SLOTS	INCLUDED
#365355	+0.75mm	1 SLOT	OPTION
#365353	0mm	0 SLOTS	OPTION
#365354	-0.75mm	Lightw.	OPTION
#365361	-1.25mm	Lightw.	OPTION

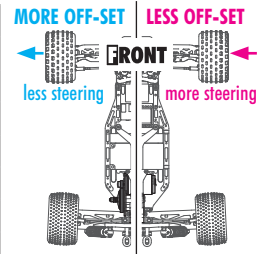

**OPTIONAL HEX HUB EFFECTS**  
Different off-set hex hubs are used to increase or decrease the track-width.



902312  
SH M3x12

2x L=R

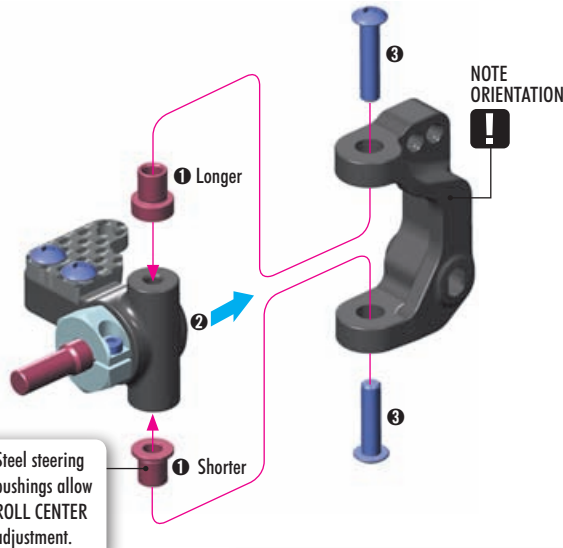

Steel steering bushings allow ROLL CENTER adjustment.

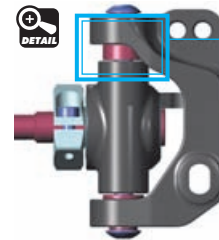

### LOWER ROLL CENTER

(INITIAL SETTING)

TOP = LONGER bushing  
BOTTOM = SHORTER bushing  
Recommended for rough tracks to improve stability.

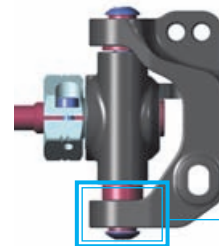

### HIGHER ROLL CENTER

TOP = SHORTER bushing  
BOTTOM = LONGER bushing  
Recommended for smooth tracks to gain more steering.



### C-HUBS

#322210-M	RIGHT	MEDIUM	OPTION
#322210-H	RIGHT	HARD	INCLUDED
#322210-G	RIGHT	GRAPHITE	OPTION
#322220-M	LEFT	MEDIUM	OPTION
#322220-H	LEFT	HARD	INCLUDED
#322220-G	LEFT	GRAPHITE	OPTION



MEDIUM - For low traction. More steering on low grip.  
HARD - For medium traction. More steering, more free in corners.  
GRAPHITE - For high traction. More precise steering, less stoping in corners.



306219  
SHIM 3x6x1



902254  
SH M2.5x4

2x L=R



CUTAWAY VIEW

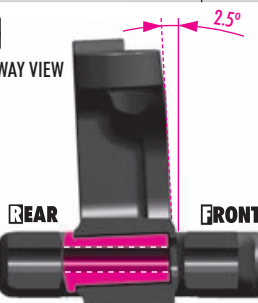

LESS CASTER = increased steering off-power  
MORE CASTER = less steering off-power

### CASTER ECCENTRIC BUSHINGS

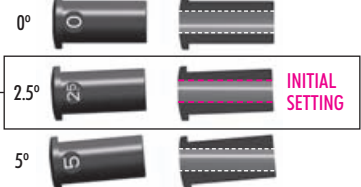

# 5. FRONT SUSPENSION **CARPET** **DIRT**

## ROLL CENTER LINKS

2x

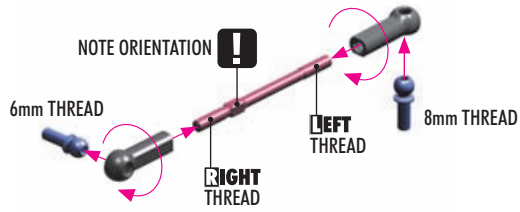

**TIP** Install the pivot balls with Professional Multi Tool (HUDY #183011).



362280  
CON. SHIM 3x6x2

## ROLL CENTER LINKS

2x

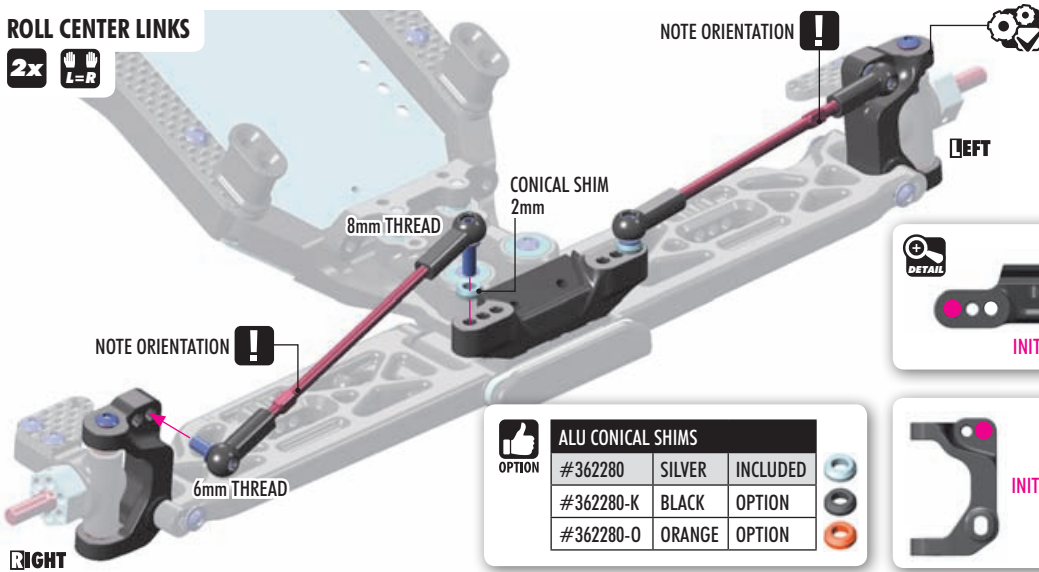

OPTION	ALU CONICAL SHIMS		
#362280	SILVER	INCLUDED	
#362280-K	BLACK	OPTION	
#362280-O	ORANGE	OPTION	

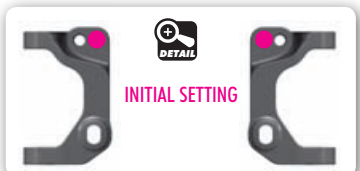

## STEERING LINKS

2x

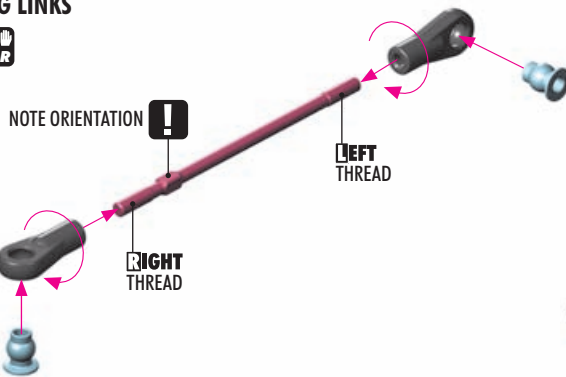

**TIP** Install the pivot balls with Professional Multi Tool (HUDY #183011).

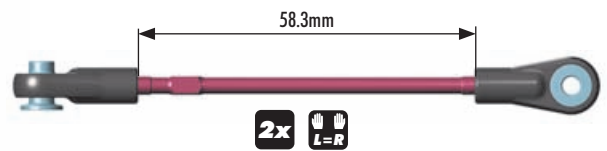

303122  
SHIM 3x6x1



903316  
SFH M3x16



960030  
NUT M3

## STEERING LINKS

2x

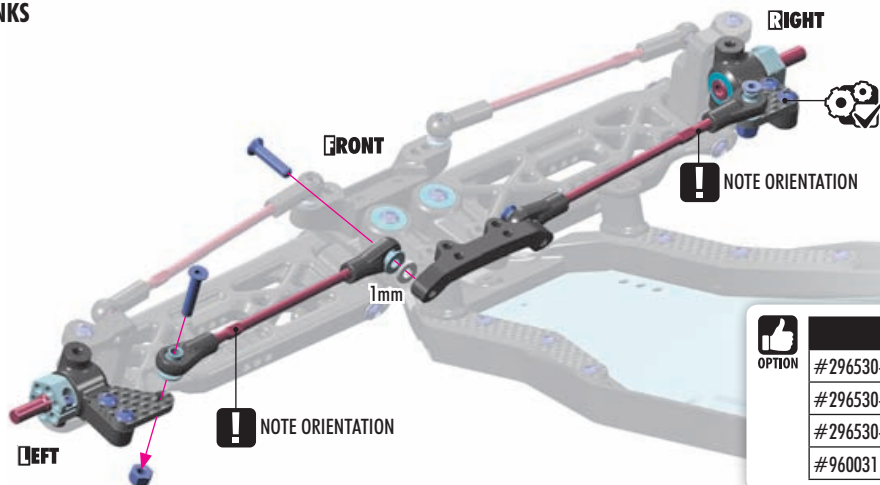

OPTION	ALU NUTS M3		
#296530-B	BLUE	OPTION	
#296530-K	BLACK	OPTION	
#296530-O	ORANGE	OPTION	
#960031	SILVER	OPTION	

# 6. SHOCK ABSORBERS **CARPET** **DIRT**

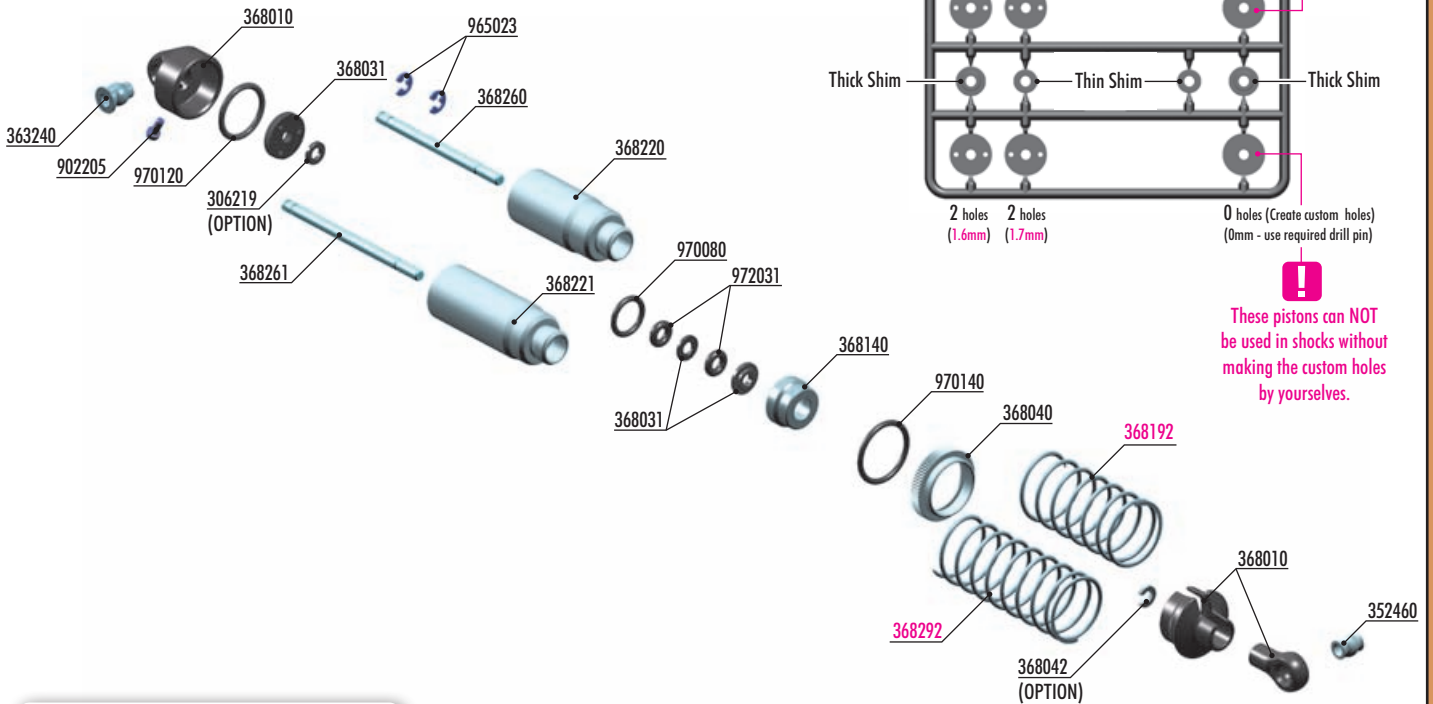

**#368042**  
**COMPOSITE SHOCK BUSHING & SHIM (2+2)**  
 OPTION

**FRONT SPRINGS**

Part #	Type	Length	Features	Status
#328192	LINEAR	49mm	2 DOTS	INCLUDED
#368175	PROGRESS.	40mm	3 DOTS	OPTION
#368182	LINEAR	45mm	1 STRIPE & 3 DOTS	OPTION
#368183	LINEAR	45mm	1 DOT	OPTION
#368184	LINEAR	45mm	2 DOTS	OPTION
#368185	LINEAR	45mm	3 DOTS	OPTION
#368186	LINEAR	45mm	4 DOTS	OPTION

**REAR SPRINGS**

Part #	Type	Length	Features	Status
#328292	LINEAR	67mm	2 DOTS	INCLUDED
#368273	PROGRESS.	60mm	2 STRIPES	OPTION
#368275	PROGRESS.	55mm	2 DOTS	OPTION
#368283	LINEAR	63mm	1 STRIPE & 3 DOTS	OPTION
#368284	LINEAR	60mm	1 DOT	OPTION
#368285	LINEAR	60mm	2 DOTS	OPTION
#368286	LINEAR		3 DOTS	OPTION
#368287	LINEAR	60mm	4 DOTS	OPTION

**#328011**  
**COMPOSITE SHOCK BALL JOINT 21MM (2)**  
 OPTION

**#972030**  
**SILICONE O-RING 3x2mm (10)**  
 OPTION

**#368052**  
**ALU SHOCK CAP-NUT WITH VENT HOLE (2)**  
 OPTION

**#104004**  
**HUDDY AIR VAC - VACUUM PUMP - 1/10 OFF-ROAD**  
 OPTION

**#368021**  
**ALU SHOCK SPRING RETAINING COLLAR (4)**  
**#368022**  
**ALU SHOCK SPRING RETAINING COLLAR -2MM (4)**  
 OPTION



- 306219 COMPOSITE SET OF SERVO SHIMS (4) (OPTION)
- 352460 PIVOT BALL 5.8 - V3 (10)
- 363240 BALL UNIVERSAL 5.8MM WITH BACKSTOP (2)
- 368010 COMPOSITE SHOCK PARTS
- 368031 SHOCK PISTONS - COMPLETE SET - DERLIN
- 368040 ALU SHOCK ADJUSTABLE NUT (2)
- 368042 COMPOSITE SHOCK BUSHING & SHIM (2+2) (OPTION)
- 368140 ALU LOWER SHOCK BODY CAP (2)
- 368200 REAR SHOCK ABSORBERS COMPLETE SET (2)
- 368220 ALU SHOCK BODY (2)
- 368221 XT2 ALU REAR SHOCK BODY (2)
- 368260 HARDENED SHOCK SHAFT (2)
- 368261 XT2 REAR HARDENED SHOCK SHAFT (2)

- 902205 HEX SCREW SH M2x5 (10)
- 965023 E-CLIP 2.3 (10)
- 970080 O-RING 8x1 (10)
- 970120 O-RING 12 x 1.0 (10)
- 970140 O-RING 14 x 1.5 (10)
- 972031 SILICONE O-RING 3x2.1 (10)

- 328192 FRONT SPRING-SET 49MM - 2 DOTS (2)**
- 328292 REAR SPRING-SET 67MM - 2 DOTS (2)**

# 6. SHOCK ABSORBERS **CARPET DIRT**

965023  
C 2.3

970080  
O 8x1

972031  
O 3x2.1

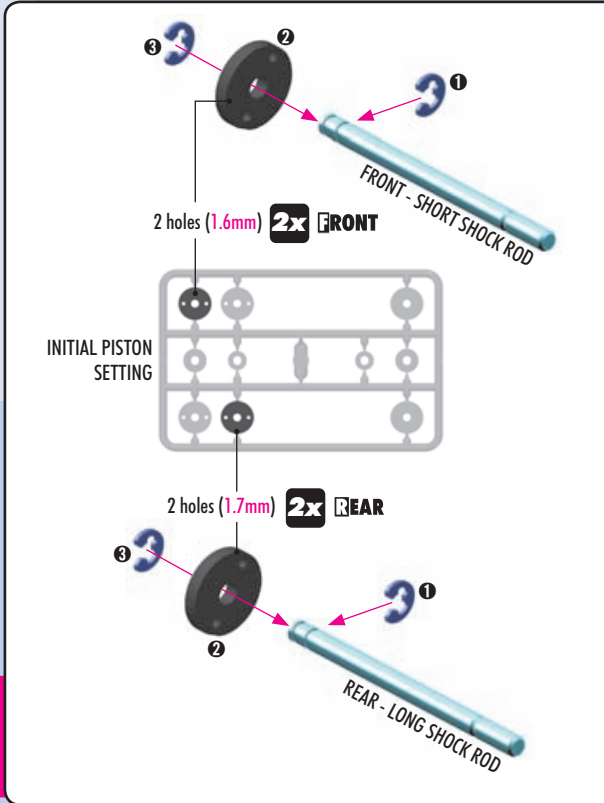

**4x**

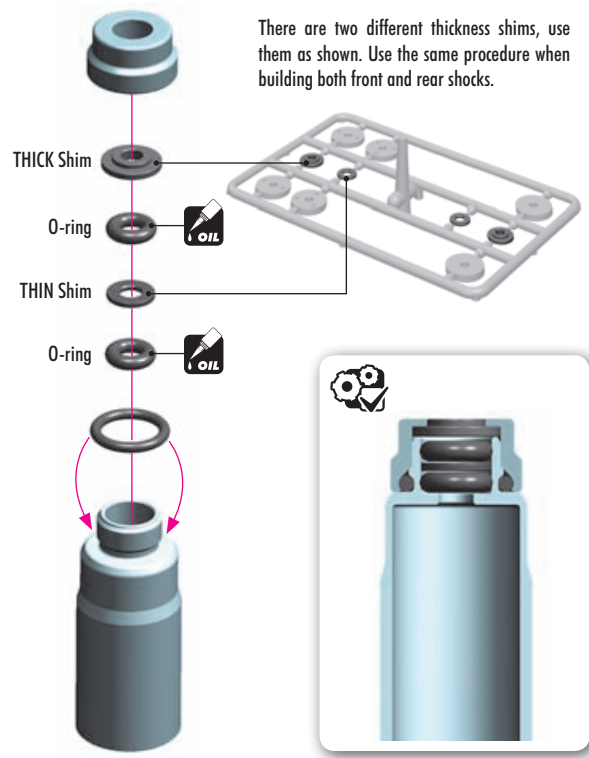

**SET-UP BOOK**  
SHOCK DAMPING  
SHOCK PISTONS

**#306219**  
OPTION DOWNSTOP SHIMS  
THICKER shim used, GREATER downstop is achieved.

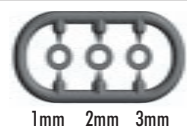

**! IMPORTANT**  
Always use same shim thickness on right and left side to achieve same downstop.

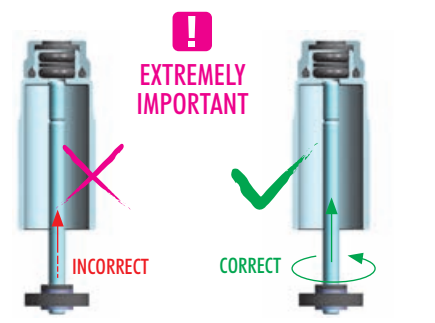
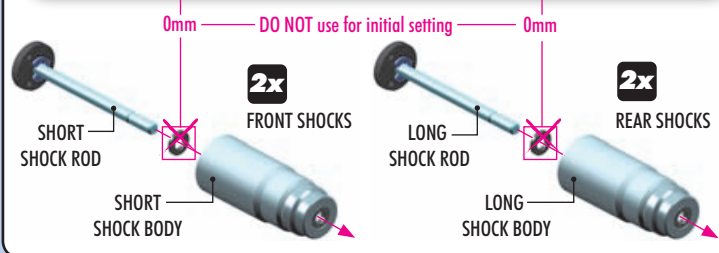

DO NOT push the shock rod straight through the lower shock body assembly; O-ring damage may result.

Twist the shock rod through the lower shock body assembly.

970140  
O 14x1.5

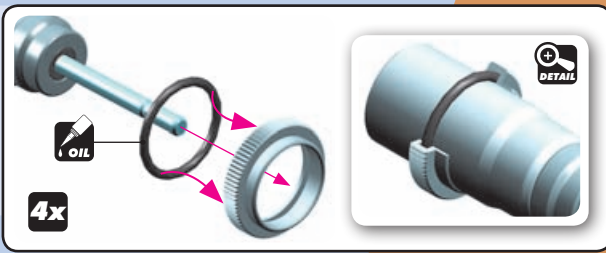

970120  
O 12x1

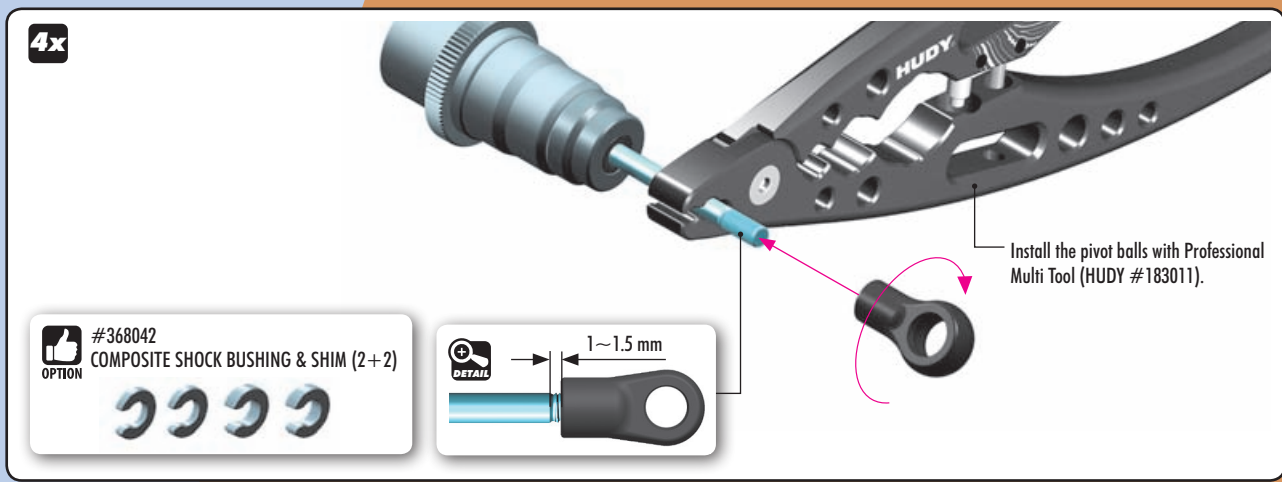
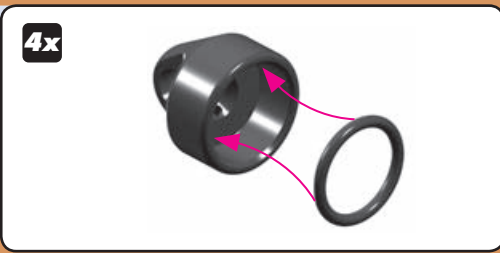



**CARPET**  
FRONT (SHORT)  
Oil 650cSt  
REAR (LONG)  
Oil 500cSt

**DIRT**  
FRONT (SHORT)  
Oil 650cSt  
REAR (LONG)  
Oil 500cSt

## DEFAULT SHOCK REBOUND SETTING 0% REBOUND

Follow the steps below to set the shock rebound to the default setting of 0%.

- Extend the shock shaft completely. Fill the shock body with the shock oil. For the FRONT shocks (short) use 650cSt oil. For the REAR shocks (long) use 500cSt oil.
- Move the shock shaft up and down a few times to release the air bubbles trapped beneath the piston.
- Orient the filled shock vertically for several minutes with the shock shaft fully extended. The remaining air bubbles will release.
- TIGHTEN FULLY  
Gently place the shock cap onto the filled shock body and start to tighten the cap. Tighten the cap fully.
- Gently push the shock shaft completely into the shock body. Excess oil will flow through the hole in the shock cap.
- Keep the shock shaft pushed in the shock body and insert the screw into the shock cap. Tighten gently.
- 6x push the shaft up and down.
- Untighten the screw.
- Gently push the shock shaft completely into the shock body. Excess oil will flow through the hole in the shock cap.
- Tighten the screw. The rebound will be at approx. 0%.

**SET-UP BOOK**  
SHOCK OIL

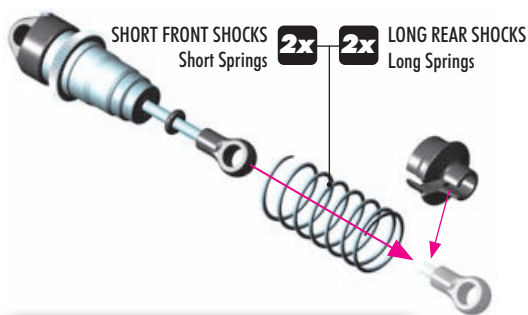

#368022  
ALU SHOCK SPRING RETAINING COLLAR -2MM (4)  
OPTION

#368021  
ALU SHOCK SPRING RETAINING COLLAR (4)  
OPTION



### IMPORTANT

Both FRONT SHOCKS must be the same overall length.  
Both REAR SHOCKS must be the same overall length.

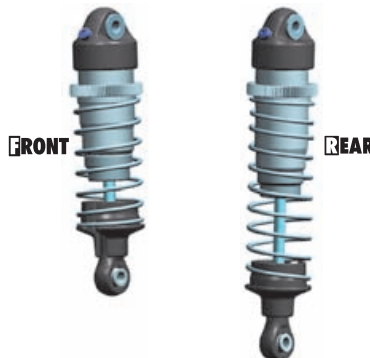

**2x** FRONT SHOCKS (SHORT)  
**2x** REAR SHOCKS (LONG)

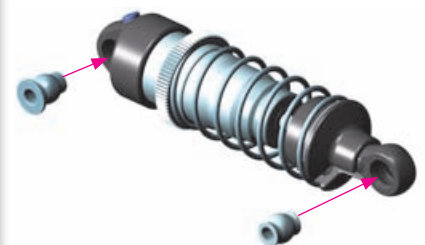



- 901308 SB M3x8

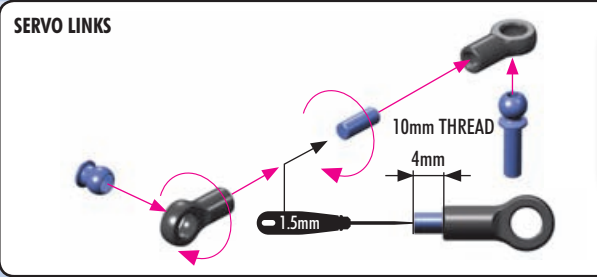

**TIP** Install the pivot balls with Professional Multi Tool (HUDY #183011).



- 303127 SHIM 3x6x4
- 362280 CON. SHIM 3x6x2
- 902308 SH M3x8
- 902312 SH M3x12
- 961032 SHIM S 3.2

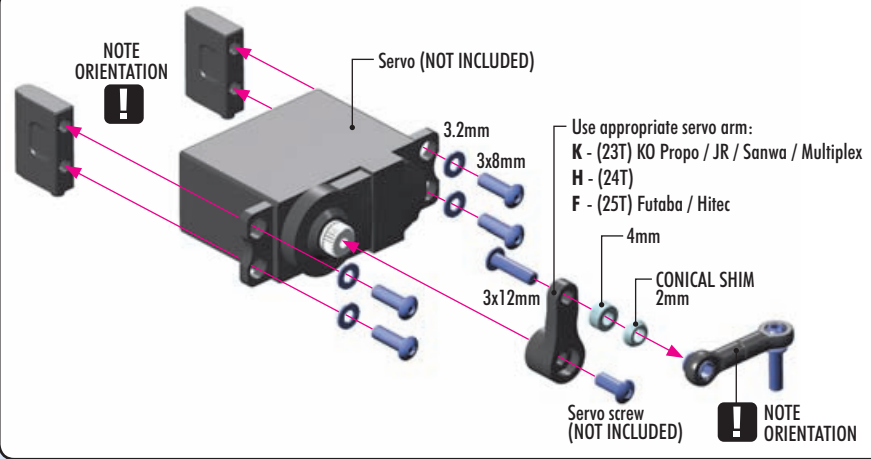

**OPTION HUDY**

HUDY ALU SERVO HORNS	
#293497	23T
#293498	24T
#293499	25T

**OPTION HUDY**

HUDY CLAMP ALU SERVO HORNS	
#293404	23T
#293405	24T
#293406	25T

For more in-corner steering and better steering response, aluminum servo horns may be used.

**TIP** For increased safety of the servo during a crash we suggest to use optional servo saver that will absorb impacts and will eliminate servo damage. To install the servo saver the optional alu stands.

**OPTION** #372503 COMPOSITE SERVO SAVER - STIFF

#372503

- 303141 SHIM 3x5x1
- 303144 SHIM 3x5x4
- 903310 SFH M3x10

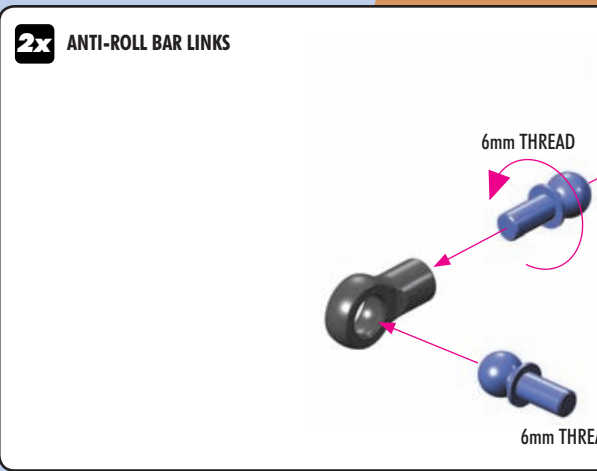
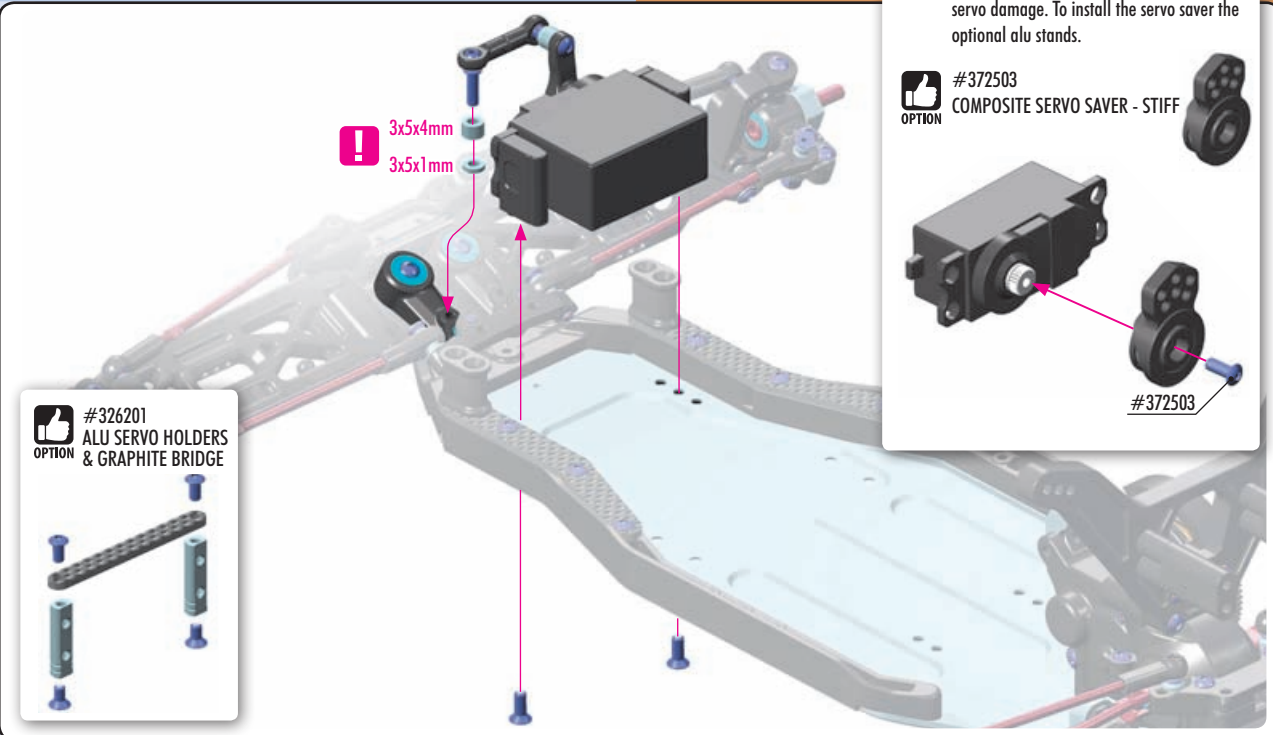



901303  
SB M3x3



### ANTI-ROLL BARS

OPTION	#322484	1.4mm	OPTION
	#322486	1.6mm	INCLUDED
	#322488	1.8mm	OPTION



901304  
SB M3x4



902308  
SH M3x8

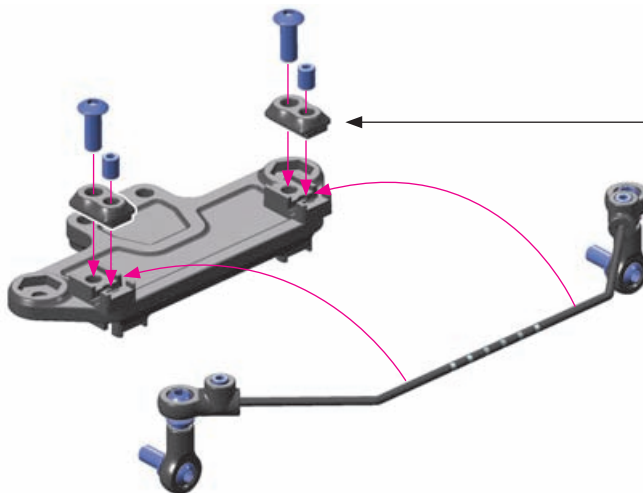

Check for free movement.

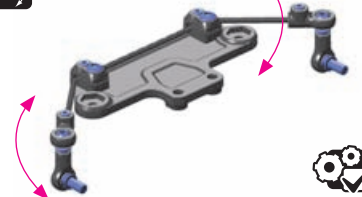

902312  
SH M3x12



902314  
SH M3x14

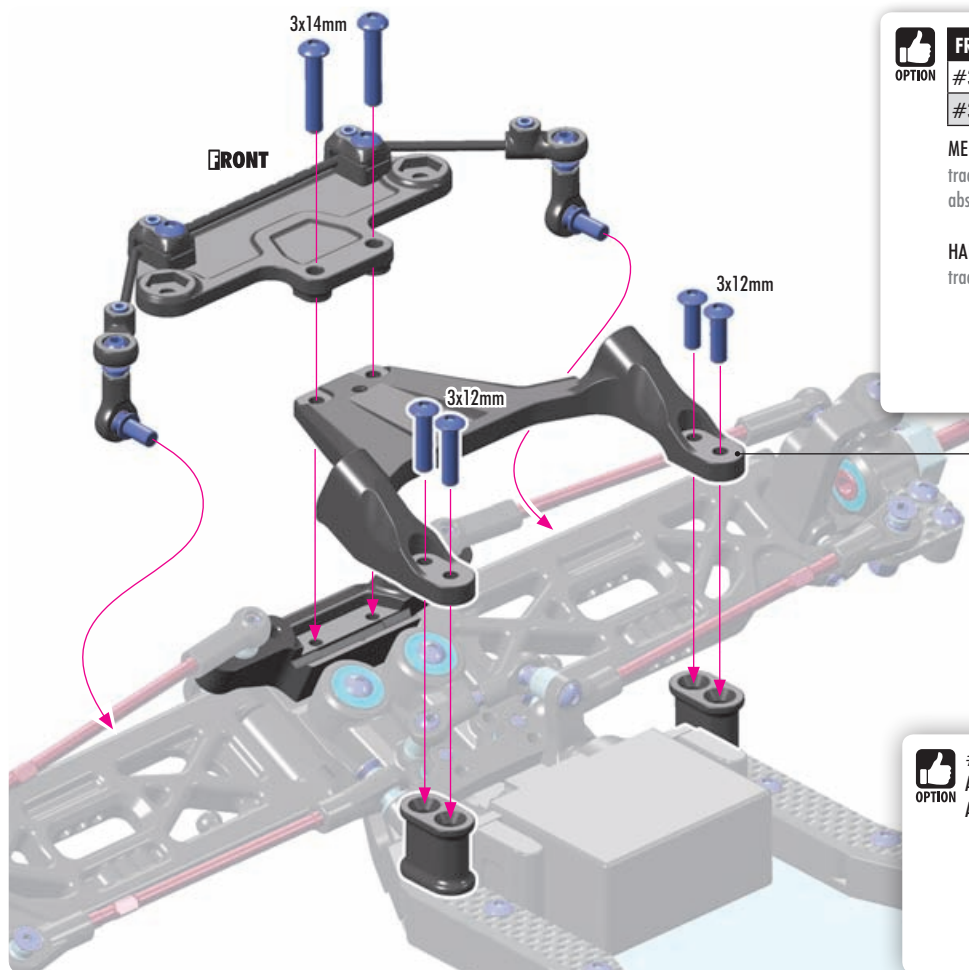

### FRONT UPPER DECKS

OPTION	#321160-M	MEDIUM	OPTION
	#321161-H	HARD	INCLUDED

**MEDIUM** - For very-low, low and medium traction tracks. Generates more traction, absorbs bumps better.

**HARD** - For high & very-high traction tracks. Makes the car more precise.



#322043  
ALU FRONT ROLL-CENTER HOLDER FOR ANTI-ROLL BAR - WIDE





# 7. FINAL ASSEMBLY

# CARPET DIRT



902310  
SH M3x10

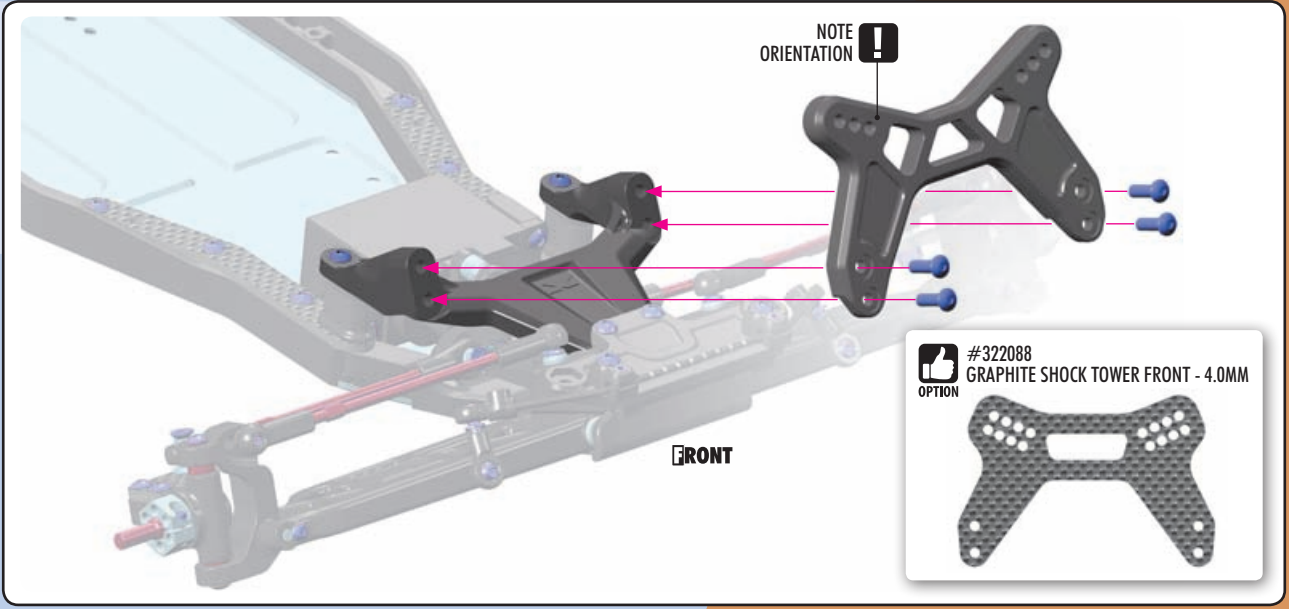

NOTE ORIENTATION

FRONT

#322088  
GRAPHITE SHOCK TOWER FRONT - 4.0MM  
OPTION



902322  
SH M3x22



960030  
NUT M3

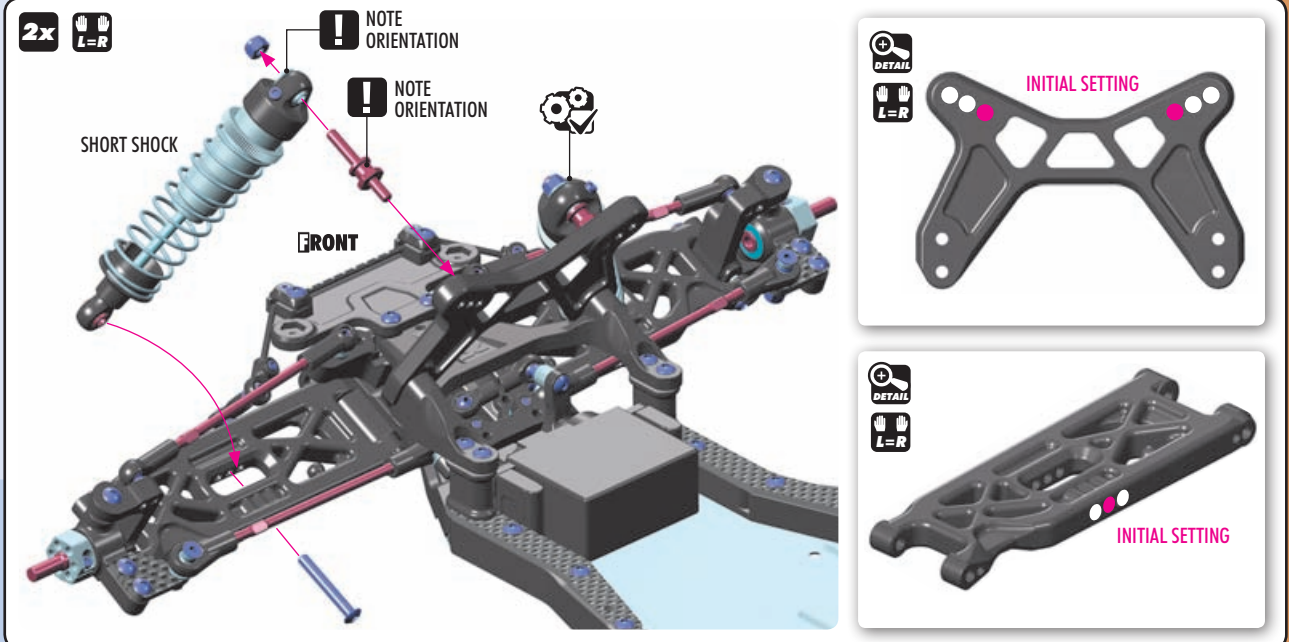

2x L=R

NOTE ORIENTATION

NOTE ORIENTATION

SHORT SHOCK

FRONT

INITIAL SETTING

DETAIL L=R



902312  
SH M3x12



960030  
NUT M3

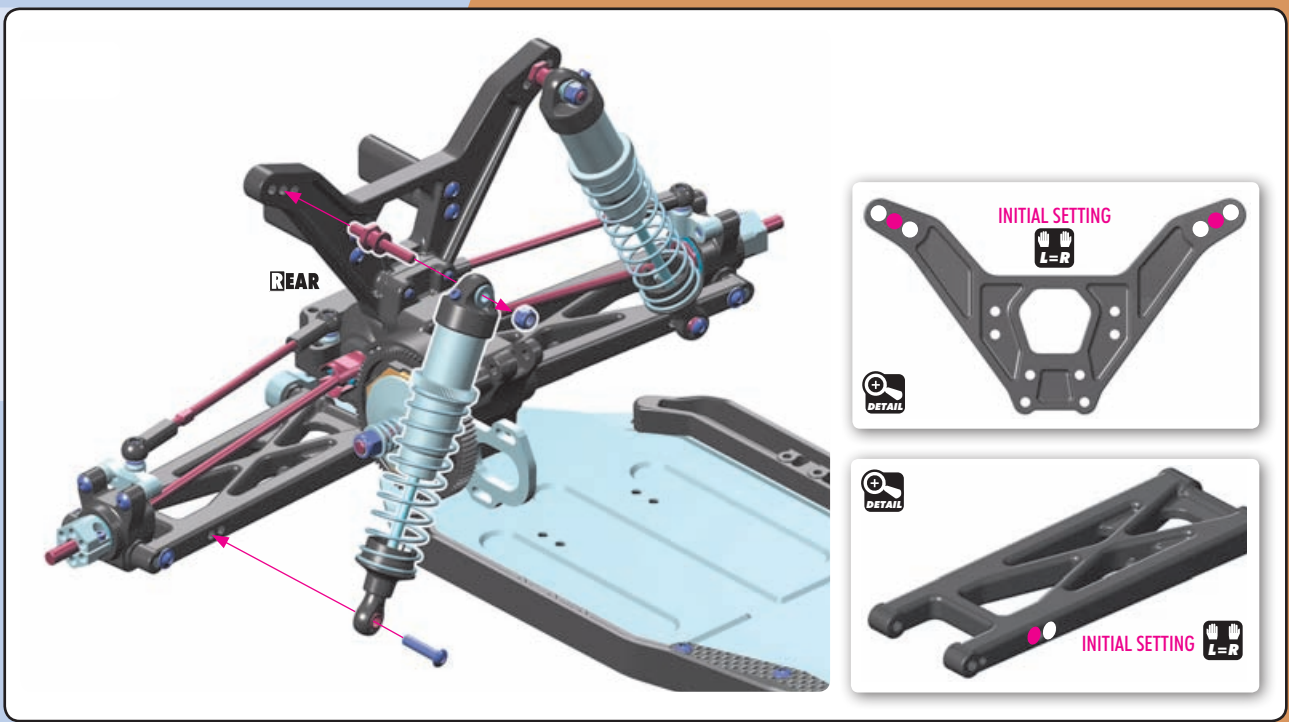

REAR

INITIAL SETTING

DETAIL L=R



REAR

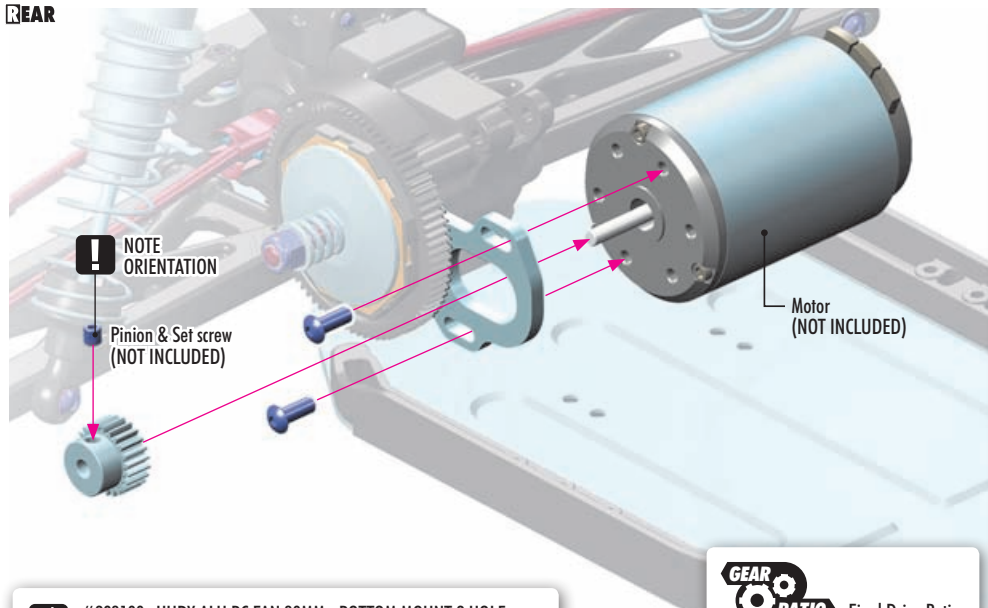

**XRAY PINIONS (48P)**

#365718	18T
#305919	19T
#294020	20T
#294021	21T
#294022	22T
#294023	23T
#305924	24T
#305925	25T
#365726	26T
#365727	27T
#365728	28T
#365729	29T
#365730	30T
#365731	31T
#365732	32T
#365733	33T
#365734	34T
#365735	35T
#365736	36T
#365737	37T
#365738	38T



- #293100 HUDY ALU RC FAN 30MM - BOTTOM MOUNT 2 HOLE
- #293101 HUDY ALU RC FAN 30MM - SIDE MOUNT 2 HOLE
- #293110 HUDY RC FAN 30MM - WITH EXTERNAL SOLDERING TABS
- #293112 HUDY RC FAN 30MM - WITH INTERNAL SOLDERING TABS



Final Drive Ratio

$$78 : X \times 2.65 = \text{FDR}$$

(Spur) (Pinion) (IGR)

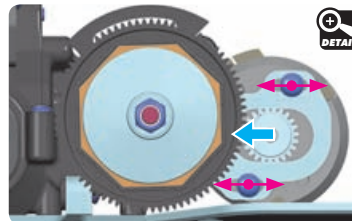

Adjust the motor so the pinion meshes with the spur gear properly. Make sure the gear mesh is not too tight.

There should be a small amount of play between the teeth of the pinion gear and the spur gear.



902310  
SH M3x10



902316  
SH M3x16



903310  
SFH M3x10

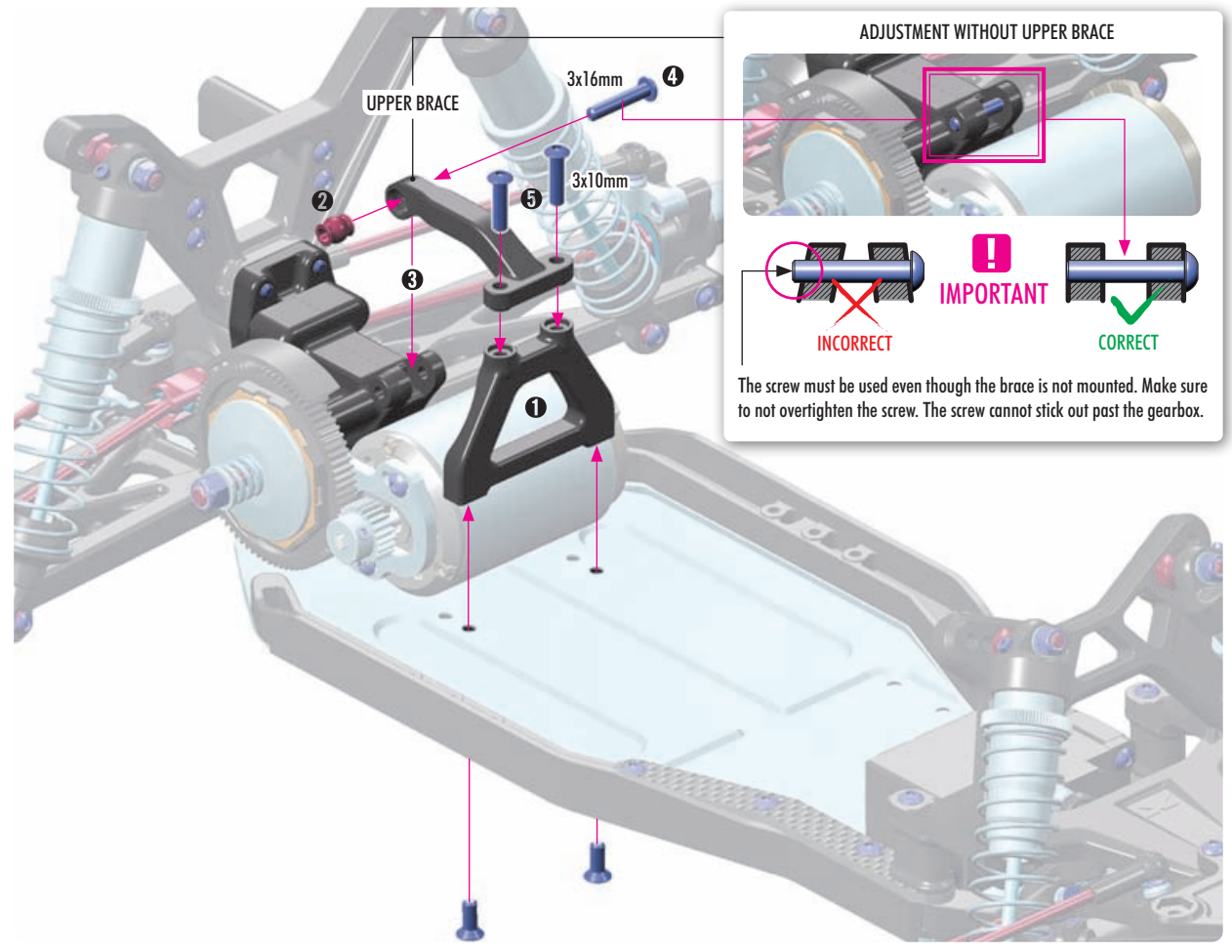

ADJUSTMENT WITHOUT UPPER BRACE



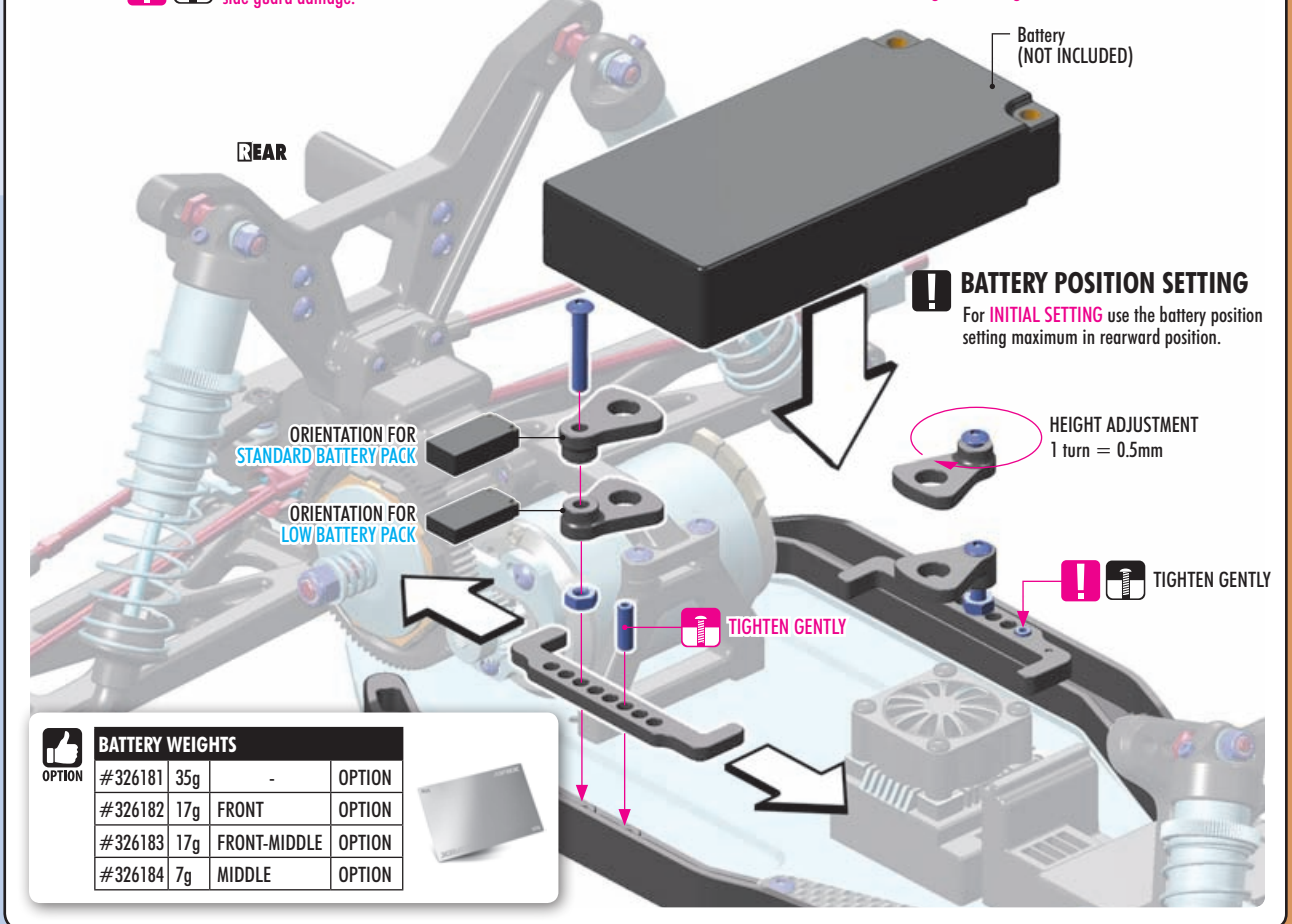
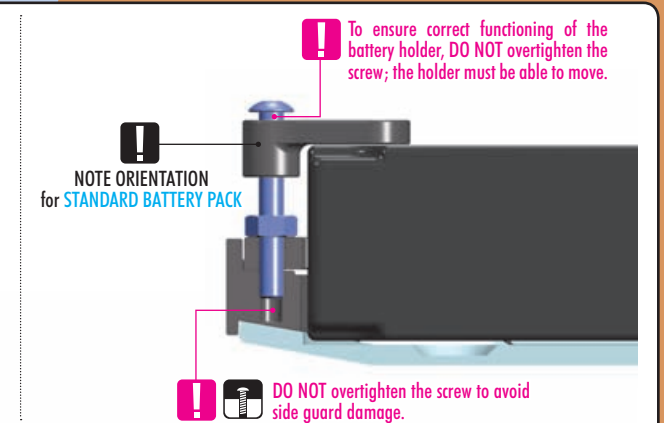
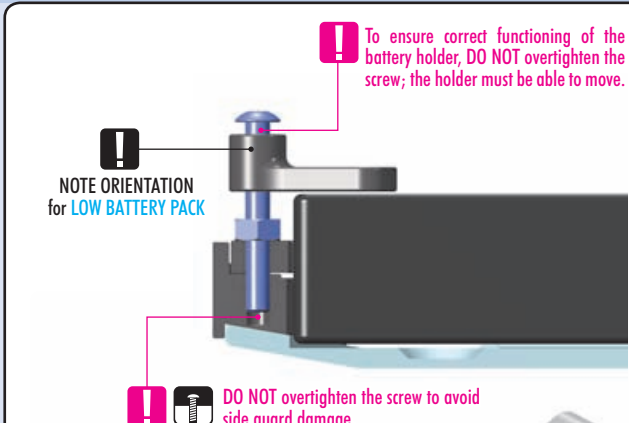
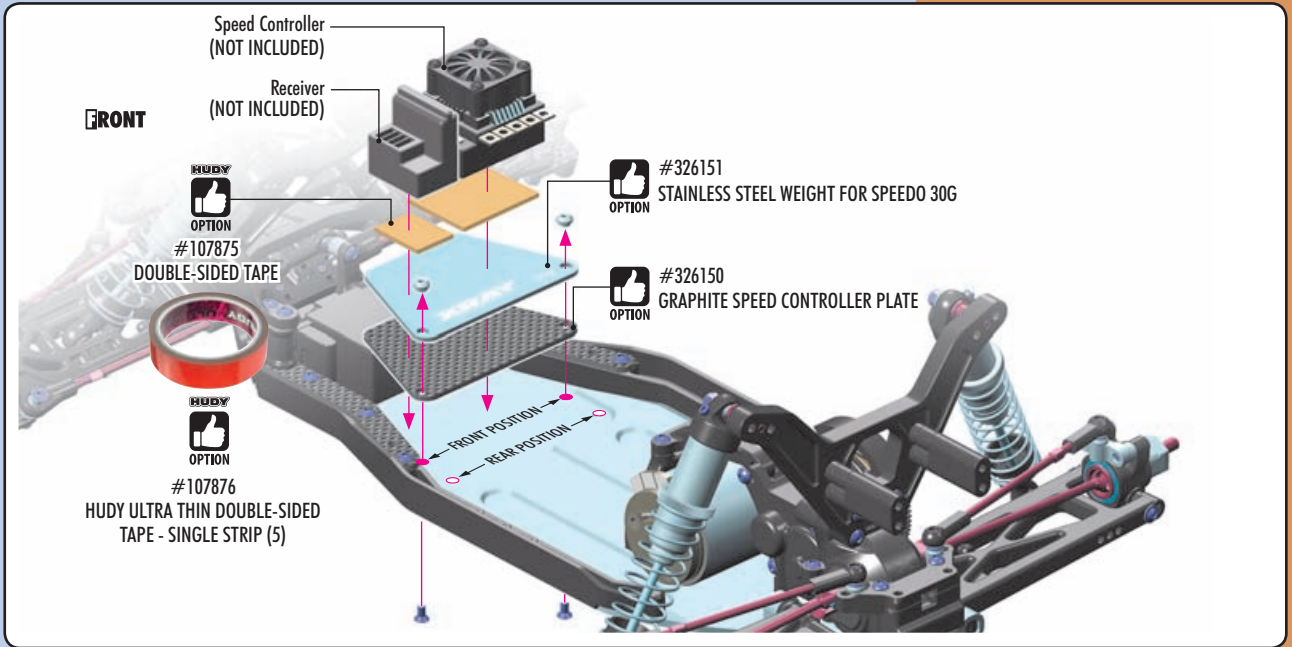

The screw must be used even though the brace is not mounted. Make sure to not over-tighten the screw. The screw cannot stick out past the gearbox.



OPTION	BATTERY WEIGHTS			
#326181	35g	-	OPTION	
#326182	17g	FRONT	OPTION	
#326183	17g	FRONT-MIDDLE	OPTION	
#326184	7g	MIDDLE	OPTION	

  
 902310  
 SH M3x10

  
 981212  
 P 2x12



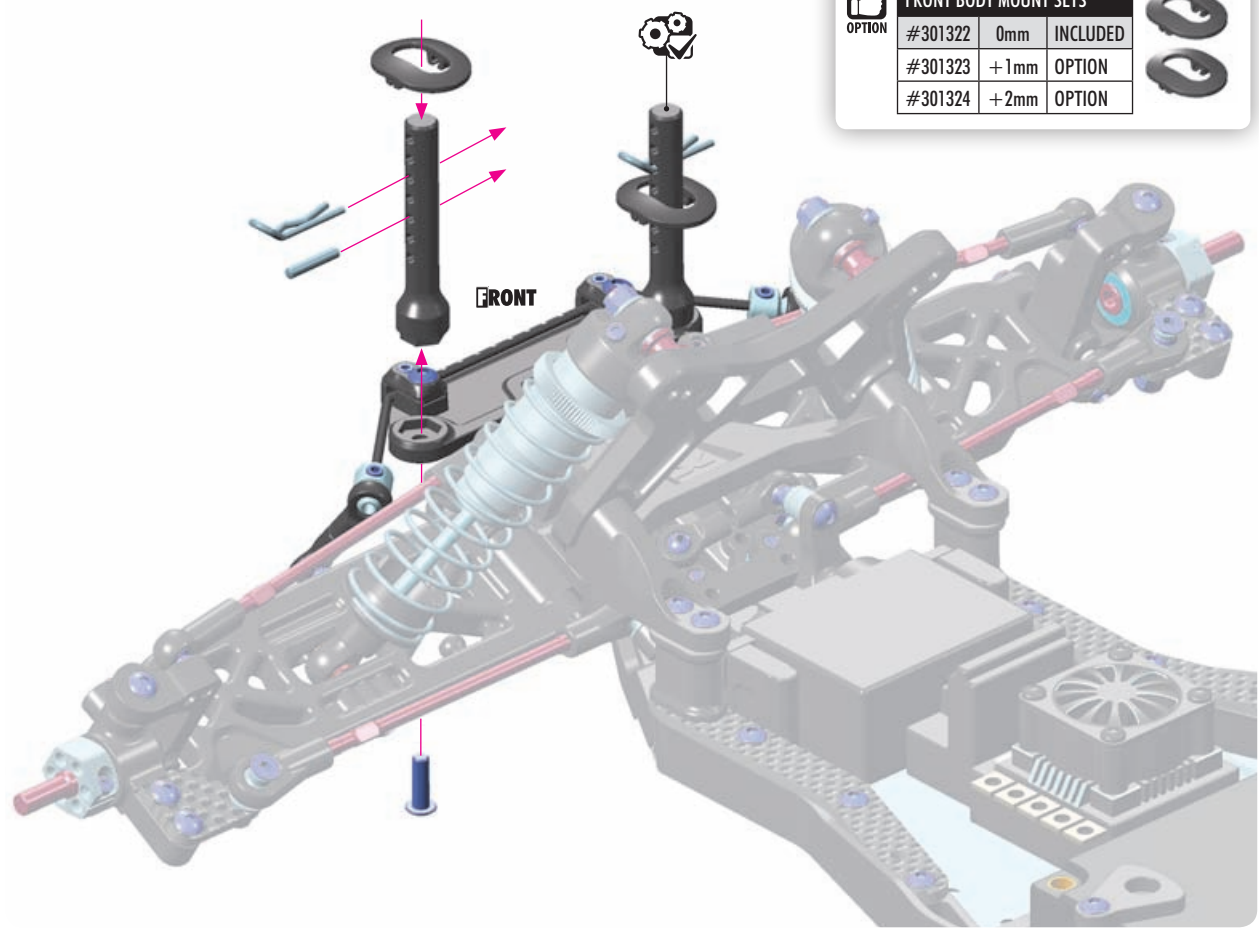



  
**FRONT**

OPTION	FRONT BODY MOUNT SETS	
#301322	0mm	INCLUDED
#301323	+1mm	OPTION
#301324	+2mm	OPTION

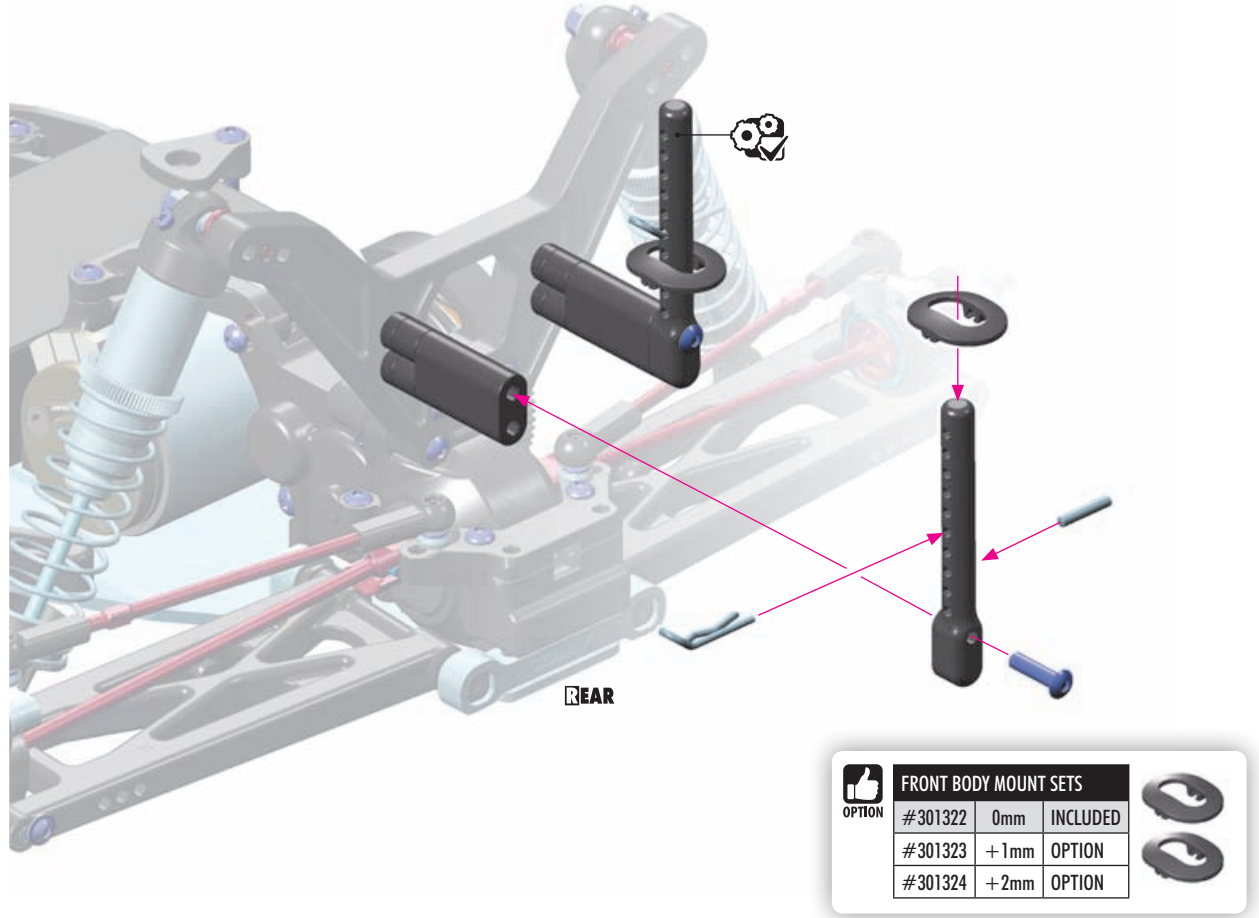

  
 902312  
 SH M3x12

  
 981212  
 P 2x12

  
**REAR**

OPTION	FRONT BODY MOUNT SETS	
#301322	0mm	INCLUDED
#301323	+1mm	OPTION
#301324	+2mm	OPTION

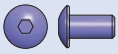

902306  
SH M3x6



308019  
NUT M3

- 1 Before cutting and making holes on the BODY, put the unpainted body on the chassis to confirm the mounting position and location for holes and cutouts. Before cutting and making holes on the WING, put the unpainted wing on the wing holders to confirm the mounting position and location for holes and cutouts.
- 2 Before painting, wash the inside of the body with mild detergent, and then rinse and dry thoroughly.
- 3 Mask all windows.
- 4 Apply paint masks as appropriate.

- 5 Paint the body using paints formulated for polycarbonate bodies.
- 6 When the paint is dry, remove the masking.
- 7 Carefully cut out the body using appropriate scissors or cutting tools.
- 8 When you have finished cutting, peel off the external protective films.
- 9 Assembly rear wing.

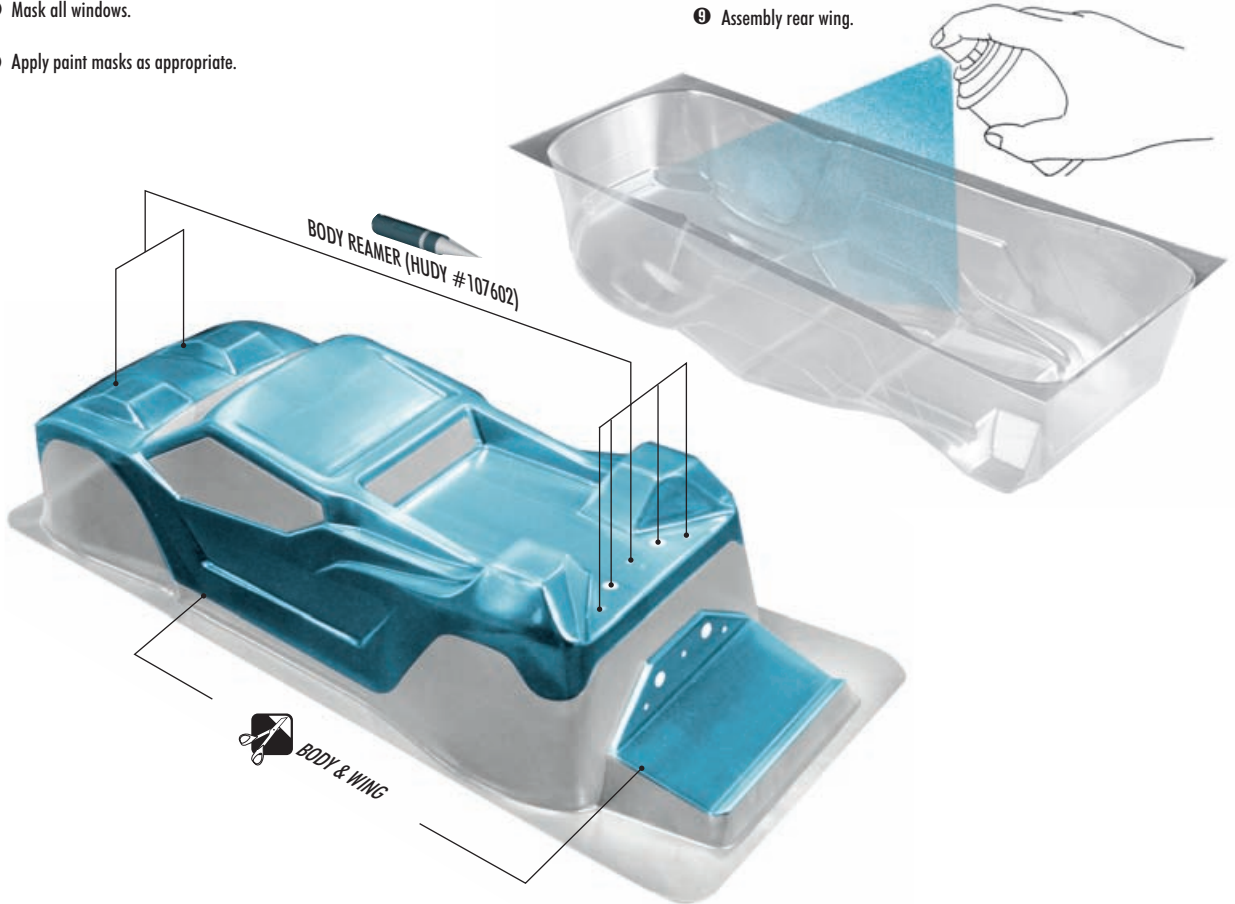

BODY STADIUM TRUCK				
OPTION	#329704	1.0mm	F/R SHOCK POSITION	INCLUDED
	#329705	0.75mm	F/R SHOCK POSITION	OPTION

REAR WINGS			
OPTION	#323520	HIGH	OPTION
	#323521	LOW	OPTION

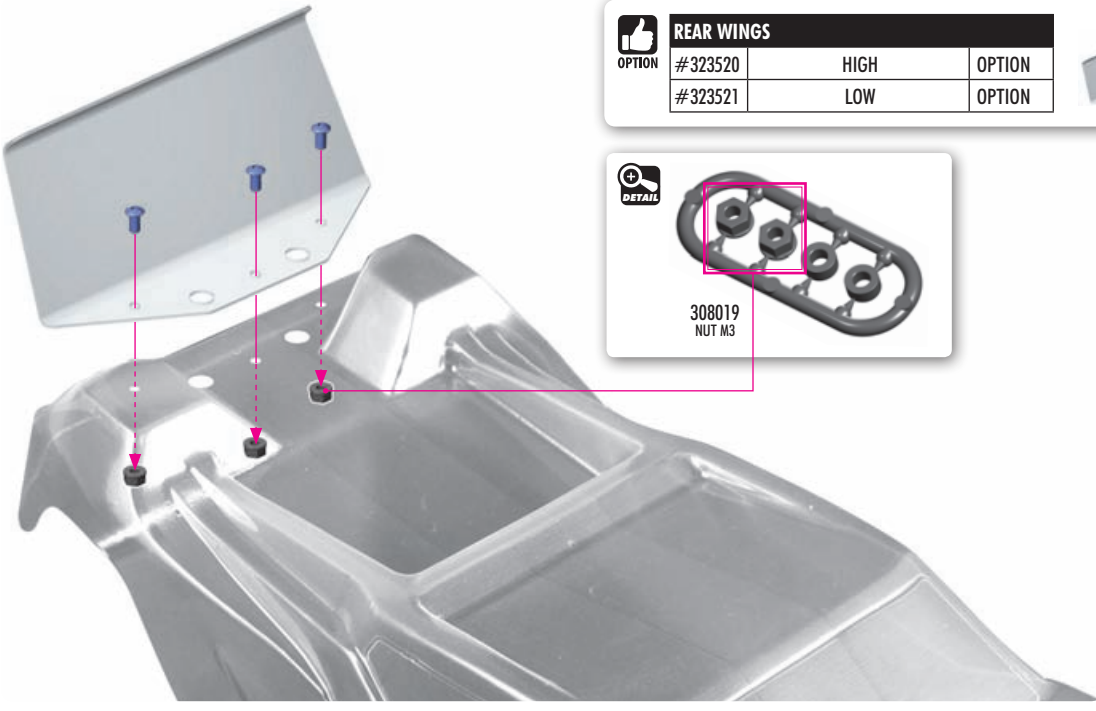
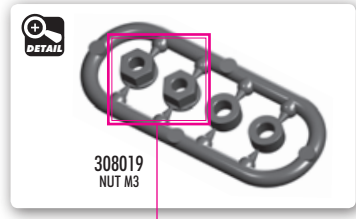

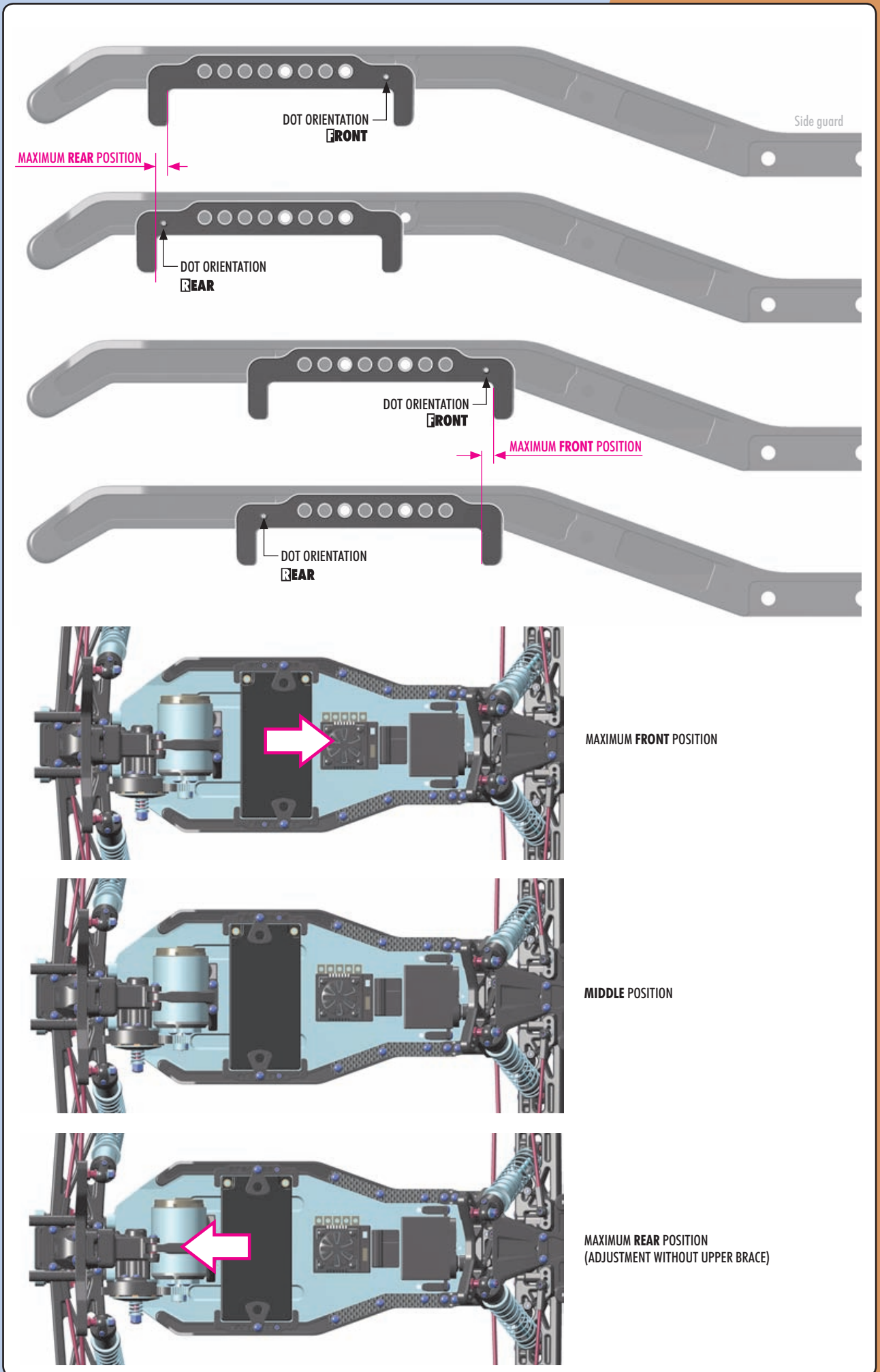

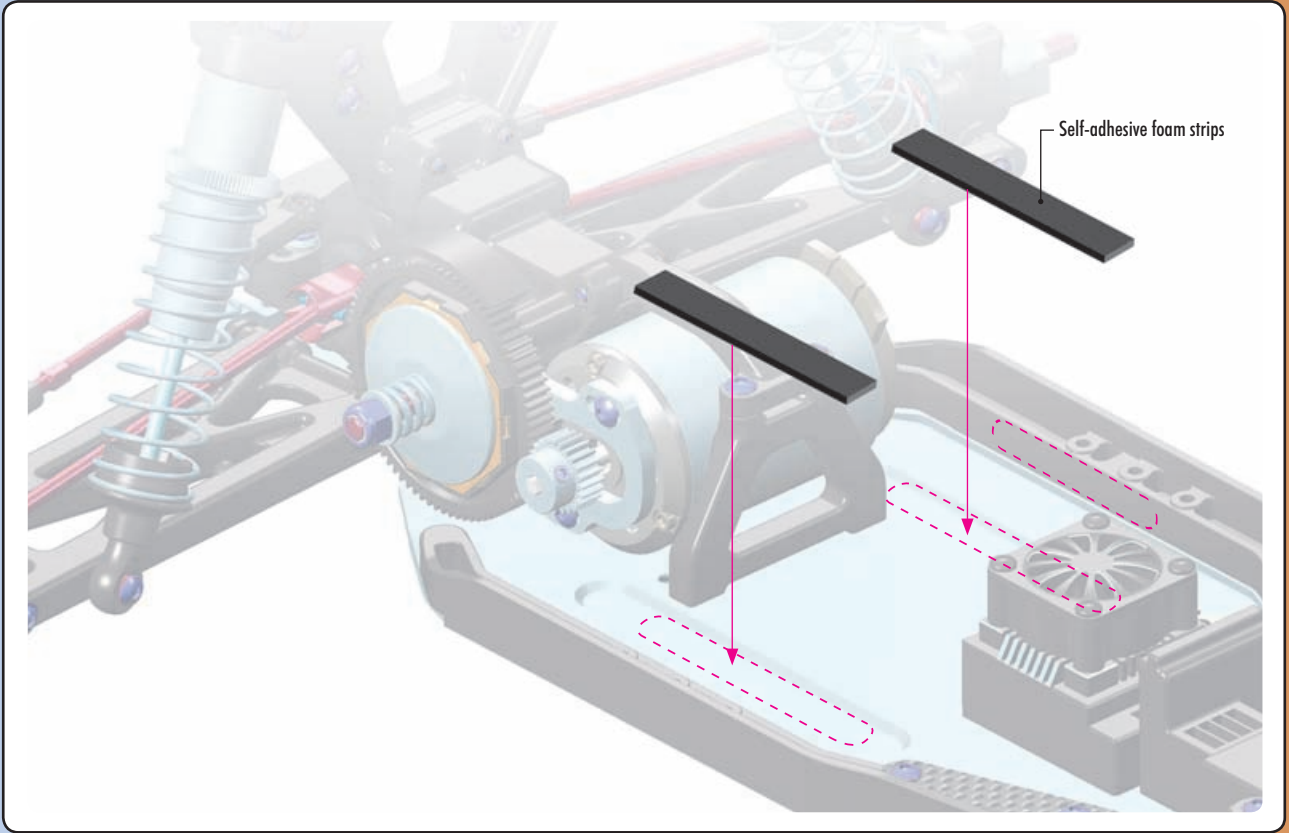

960240  
N M4

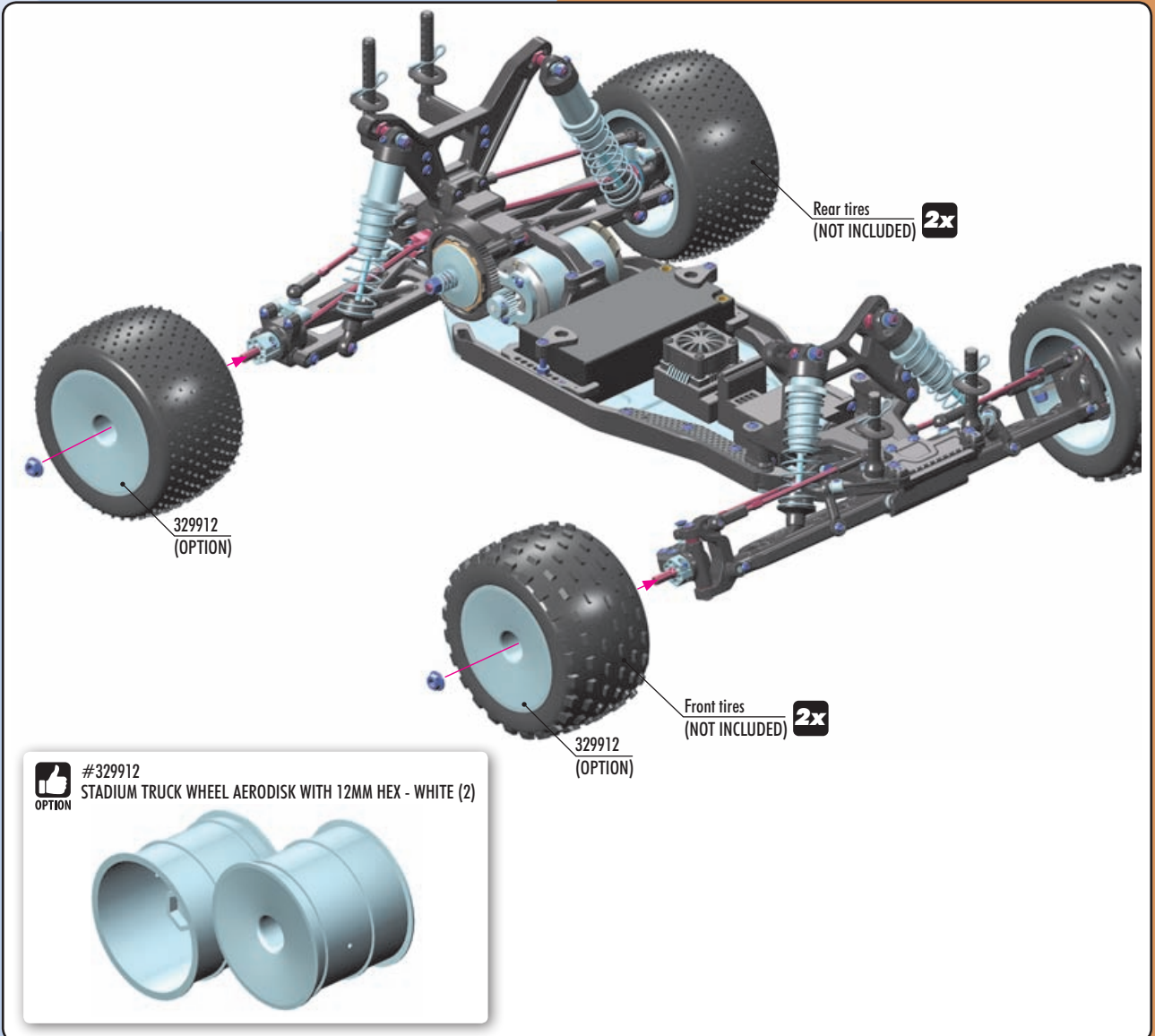

## SHOCK MAINTENANCE

The most important maintenance task for keeping consistent shock performance is refilling and bleeding them correctly. If built correctly, it will not be necessary to re-build them often. Replacing warped/hard o-rings, scarred piston rods, or shaved/split/loose composite upper and lower ball joints are also important.

- For club racing, it is recommended to check the shocks for air inside before each race and only re-fill and bleed them if necessary. Before each race day, make sure you take the spring off of each shock, hold it up to your ear, and quickly compress the shock rod fully into the body while listening for any air making a "whistling" or "squishy" sound as it passes through the piston holes. If you hear any air, refill and bleed your shocks. For high-competition racing, it is recommended that the shocks be re-filled and bled before a large event.
- If building or pairing new shocks, always make sure they are the same length using a shock length measuring tool and adjust the lower ball joints as needed.
- During regular shock operation, oil naturally gets on the shock shaft and drop-by-drop slightly gets out of the shock body. Shocks should be inspected regularly after each race, and oil replaced as required.

## BEARING MAINTENANCE

Ball-bearings in an off-road car must be properly maintained for smooth operation and long lifespan.

The ball-bearings are degreased and are lubricated with HUDY Bearing Oil or HUDY Grease. The following procedures are recommended to clean all of the bearings in your off-road car. For high-competition racing, we recommended doing this every 3-4 weeks, or before a major race.

- 1 Remove the seals on both sides of the bearing (if present). If the seals bend a little and you can see a kink, carefully flatten the kink out by hand.
- 2 Spray the seals with motor cleaner and blow dry with compressed air.
- 3 Spray the bearing on both sides with motor cleaner.
- 4 Spin the bearing while it is still wet to dislodge any particles with the cleaner.
- 5 Spray the bearing on both sides again.
- 6 Blow both sides of the bearing dry with compressed air to make sure particles come out.
- 7 Hold the inner part of the bearing with my left thumb/forefinger and spin it to make sure it spins free without any abnormal vibrations or sounds.
- 8 Place one drop of bearing oil into each side of the bearing.
- 9 Replace both seals at the same time by lining them up on each side of the bearing and lightly pressing them in all the way around the bearings circumference with your thumb and forefinger. Do not press too hard or use any type of tool, such as a wrench tip, to push the blue seals in as they will push in too far, bend and cause drag.

If you spin test the bearing after you have re-oiled and sealed it, it will not spin freely for an extended period of time. The lightest of oils may allow it to spin for 1-2 seconds. This is normal and once you have mounted the bearings in the car again, the drive train will spin freely.

Make sure you use a motor cleaner that does not leave a residue after it dries as this may cause drag and wear in the bearings.

### RECOMMENDED PRODUCTS

- Use correct oil or grease to lubricate the bearings:  
 #106230 HUDY Bearing Oil  
 #106220 HUDY Bearing Grease - Standard  
 #106221 HUDY Bearing Grease - Blue  
 #106222 HUDY Bearing Grease - Red



## SUSPENSION & DRIVETRAIN MAINTENANCE

- Check suspension for free movement during building and operation, and especially after running and if you have crashed the car. If the suspension does not move freely, use the appropriate HUDY Arm Reamer to clean and resize the holes of the suspension arms.
- Regularly check the drive shaft pins and if they show any wear must be immediately replaced by new pins. If the car is run with worn pins, excessive wear on the diff outdrives will result. The #106000 HUDY Drive Pin Replacement Tool (for 3mm Pins) is a compact, rugged multi-use tool set for replacing 3mm drive pins in drive shafts. Use the HUDY replacement drive shaft pins 3x12 (#106051).
- Regularly inspect and replace the pins that connect the wheel drive shafts with wheel axles. Use HUDY Graphite Grease to lubricate the drive shaft connecting joints and the diff gears.
- Pivot balls and ball-joints will naturally wear for some time and will generate play. If there is too much play the pivot balls and ball joints need to be replaced.
- If the car is run in wet conditions, apply WD-40® on all drivetrain parts before the run. After the run, clean and dry the parts again.



#106210 HUDY GRAPHITE GREASE



or #106213 HUDY JOINT GREASE

## HUDY SPRING STEEL™

The HUDY Spring Steel™ used in the car is the strongest and most durable steel material on the RC market. While items made from HUDY Spring Steel™ are still subject to wear, the lifespan is considerably longer than any other material. As parts made from HUDY Spring Steel™ wear, the

brown color will fade (get lighter) but it will not affect the strength of the material. The brown color is only a surface treatment and if the brown color will wear the durability of the part will be still strong.





EXCLUSIVE PROFESSIONAL

# HUDY

108605 - BLACK

108601 - GREY

108603 - DARK GREY

108602 - SILVER GREY

108604 - TITAN

199183

104004

107701

106000 + 106036

109801

181090

107740

293100

293101

293110

293112

107742

181030

104004 HUDY AIR VAC - VACUUM PUMP - 1/10 OFF-ROAD  
105500 HUDY UNIVERSAL TIRE BALANCING STATION  
105520 WHEEL ADAPTER FOR 1/10 TOURING CARS - 12MM  
106000 HUDY DRIVE PIN REPLACEMENT TOOL (FOR 3MM PINS)  
106036 EJECTOR PIVOT PIN & ALTERNATING PIVOT 2.5MM FOR #106000  
107090 HUDY BEARING CHECKING TOOL  
107601 LIMITED EDITION - REAMER FOR BODY Ø-9MM + COVER - SMALL  
107701 CHASSIS DROOP GAUGE SUPPORT BLOCKS 20MM FOR 1/8 - LW(2)  
107740 HUDY ADJUSTABLE RIDE HEIGHT GAUGE 14-20MM  
107742 HUDY ADJUSTABLE RIDE HEIGHT GAUGE 20-30MM  
107855 HUDY PIT LED  
107880 CHASSIS BALANCING TOOL (2)

108160 HUDY 1/10 OFF-ROAD CAR STAND - V2  
108190 HUDY ALU TRAY FOR PARTS  
108601 FLAT SET-UP BOARD FOR 1/10 OFF-ROAD - LIGHTWEIGHT - GREY  
108602 FLAT SET-UP BOARD FOR 1/10 OFF-ROAD - LIGHTWEIGHT - SILVER GREY  
108603 FLAT SET-UP BOARD FOR 1/10 OFF-ROAD - LIGHTWEIGHT - DARK GREY  
108604 FLAT SET-UP BOARD FOR 1/10 OFF-ROAD - LIGHTWEIGHT - TITAN  
108605 FLAT SET-UP BOARD FOR 1/10 OFF-ROAD - LIGHTWEIGHT - BLACK  
108901 HUDY SET-UP STATION FOR 1/10 OFF-ROAD CARS (WITH #108840)  
108960 ALU NUT FOR 1/10 OFF-ROAD SET-UP SYSTEM (4)  
109801 HUDY ALU TRAY FOR 1/10 OFF-ROAD DIFF & SHOCKS  
109840 HUDY ALU TRAY FOR 1/10 OFF-ROAD DIFF ASSEMBLY  
109860 HUDY ALU TRAY FOR SET-UP SYSTEM



[www.teamxray.com](http://www.teamxray.com)

**XRAY EUROPE**

XRAY, K VÝSTAVISKU 6992, 91101 TRENCIN, SLOVAKIA, EUROPE  
PHONE: +421-32-740 11 00, FAX: +421-32-740 11 09, [info@teamxray.com](mailto:info@teamxray.com)

**XRAY USA**

RC AMERICA, 2030 Century Center Blvd #15, Irving, TX 75062, USA  
PHONE: 214-744-2400, FAX: 214-744-2401, [xray@rcamerica.com](mailto:xray@rcamerica.com)

